

How to Cite:

Kaur, N., Mushtaq, M., & Khurshaid, S. Z. (2022). Comparison of biomechanical differences by FEM between labial and lingual orthodontic mechanotherapy involved in canine retraction. *International Journal of Health Sciences*, 6(S9), 4127–4146. <https://doi.org/10.53730/ijhs.v6nS9.13620>

Comparison of biomechanical differences by FEM between labial and lingual orthodontic mechanotherapy involved in canine retraction

Dr Nameeta Kaur

Lecturer, Department of Orthodontics and Dentofacial Orthopedics, Government Dental College and Hospital, Srinagar, Kashmir (J & K)

Corresponding author email: nameetakaur@gmail.com

Dr Mohammad Mushtaq

Professor & Head, Department of Orthodontics and Dentofacial Orthopedics, Government Dental College and Hospital, Srinagar, Kashmir (J & K)

Dr Syed Zameer Khurshaid

Associate Professor, Department of Orthodontics and Dentofacial Orthopedics, Government Dental College and Hospital, Srinagar, Kashmir (J & K)

Abstract---*Introduction*- FEM is a mathematical method in which the shape of complex geometric objects and their physical properties are computer-constructed. Physical interactions of the various components of the model can then be calculated in terms of stress and strain, detailed information which is difficult to obtain by any other experimental or analytical means due to the interaction of anatomical structures with the surrounding tissue. *Aim*- Comparison of biomechanical differences by FEM between labial and lingual orthodontic mechanotherapy involved in canine retraction. *Material & Method* - ANSYS software was preferred over others for the analysis. As ANSYS can import computer assisted designing (CAD) data and also enables to build geometry, in the current study, we have shown the simulated individual (sequential) canine retraction using the sliding (friction method) mechanics by an elastic component. Sliding mechanics was preferred over the closing loop mechanics (frictionless method) *Results*- Stress in the PDL and Alveolar bone were calculated and depicted. *Conclusion*- On retraction, the high stress was produced with the Labial system in the PDL and alveolar bone that gradually reduced on force degradation. On combined force application slight increase in stress was noticed.

Keywords---FEM, Retraction, Stress.

Introduction

In this era of progression, the truths of today become the myths of tomorrow; practitioners of a scientific discipline are generally resistant to accept a new paradigm. Nonetheless after a paradigm shift has occurred, a veritable explosion of new ideas and information occurs, leading to rapid advances in the field. Orthodontics as of today is on a threshold of virtual deluge of knowledge, flowing in at a rapid pace.

Current options for invisible orthodontic appliances include clear brackets, clear aligners, and lingual braces. The use of clear brackets has grown due to the esthetic improvement over conventional metal brackets.^{1,2} Nevertheless, lingual appliances have their own peculiar biomechanics, distinct from that of conventional orthodontics, and special care must be taken in their application.^{3,4} The immediate problem that confronted lingual orthodontics at its earliest stages was the inaccuracy of bracket positioning. It is well known that the key factor for successful orthodontic treatment is precise bracket positioning, especially when more treatment is built into the brackets. Therefore, many efforts have been made to improve the accuracy of lingual bracket positioning. Unlike the labial bracket, the lingual bracket has a position closer to the center of resistance of the tooth, thus allowing easier movement whenever a force is applied.⁵

The friction method (sliding mechanics) is based on the cuspid bracket sliding on a sectional wire from cuspid to second molar. It is nearly two thousand years since the phenomenon of tooth movement in response to an applied load was first reported (Celsus, 1st century AD). The initiating factor for biological changes is the stress induced in the periodontal tissue; hence it is important to investigate the stress levels from orthodontic forces in the periodontal tissues.⁶ It is very difficult to measure clinically the stress induced at various locations within the root by different types of orthodontic tooth movement. Although a variety of traditional analytical and experimental methods for analyzing dental stresses, such as photoelasticity, interferometric holography, and strain gauges, have shed some light on the mechanism of orthodontic tooth movement, they have been unable to clarify the microenvironmental changes around the PDL and within the bone.⁷

The finite element method (FEM) described by Zienkiewicz has been used to investigate a wide range of topics in dentistry.⁸ FEM is a mathematical method in which the shape of complex geometric objects and their physical properties are computer-constructed. Physical interactions of the various components of the model can then be calculated in terms of stress and strain, detailed information which is difficult to obtain by any other experimental or analytical means due to the interaction of anatomical structures with the surrounding tissue.⁹

This research study was conceptualized with the idea to incorporate a mathematical model using Finite Element Analysis to identify the stress and strain generated in the supporting periodontal tissues of maxillary permanent cuspid in response to orthodontic forces delivered via lingual and labial fixed orthodontic mechanotherapy.

Aims & Objective

The present study was undertaken with the following aims and objectives:

1. Develop an accurate and validated 3D FEM computer model of right maxillary canine, labial orthodontic bracket (MBT bracket with .022X.028" slot) and lingual orthodontic bracket (STB bracket with .018X.018" slot).
2. Develop a 3D computer simulation of maxillary canine retraction using the Finite Element Method (FEM).
3. Assessment of stresses in the periodontal ligament and alveolar bone of the maxillary canine caused by retraction forces of 150 grams by sliding mechanics in labial orthodontics by FEM.
4. Assessment of stresses in the periodontal ligament and alveolar bone of the maxillary canine caused by retraction forces of 150 grams by sliding mechanics in lingual orthodontics by FEM.
5. Comparison of biomechanical differences by FEM between labial and lingual orthodontic mechanotherapy involved in canine retraction.

Materials & Method

This study was conducted in the Department of Orthodontics and Dentofacial Orthopedics, Government Dental College & Hospital, Srinagar with technical assistance from Lelogix Design Solutions Pvt. Ltd.

Armamentarium

1. Right maxillary canine tooth
2. Labial orthodontic canine bracket (MBT) (Fig: 1)
3. Lingual orthodontic canine bracket (STB) (Fig: 2)
4. Computational facilities (Fig: 3)

Hardware – A PC workstation having:

- a) 4th Generation Intel® Core™ i3-4130 Processor (3.4 GHz)
- b) Windows 8.1 Single Language (64Bit) English
- c) 4GB Single Channel DDR3 1600MHz
- d) 500GB Hard Drive
- e) Nvidia Graphics Card
- f) 18.5" LED Monitor

Software –

- g) 2D cross-section created by AutoCAD software from Autodesk Inc. (USA).
- h) 3D model of the canine and its surrounding region created by SolidWorks.
- i) ANSYS software used for Finite Element Meshing, Solving and Post processing the results.

Method

A. Fabrication of 3-D FEM Models

1. **Develop Model of Right Maxillary Canine & Supporting Structures (Fig:4, 5)**

- For modeling, the maxillary canine with the supporting structures periodontal ligament and surrounding alveolar bone was developed.
- Initially, the model of maxillary canine was created by manually designing the tooth (enamel, dentin and cementum) according to the detailed dimensions and morphology supplied by Wheeler's Textbook of Dental anatomy, Physiology and Occlusion, 9th Edition, Elsevier.⁴²
- The model of the surface contours of the tooth was then converted into a solid model using 3D modeling software SolidWorks.
- PDL was modeled as a layer 0.25 mm thick around the root surface.
- Finally, alveolar bone was modeled around the tooth and PDL.

2. Develop Model of Right Maxillary Canine Labial bracket (Fig 6, 7)

- Commercially available labial orthodontic MBT bracket (American Orthodontics) with .022 X .028" slot of right maxillary canine was selected.
- Measurements of the brackets were made using a stereo-microscope, accurate upto 0.01mm (Zoomer, SZ-790). The outer design of the labial brackets was scanned using a Breuckmann white light scanner.

3. Develop Model of Right Maxillary Canine Lingual Bracket (Fig 8,9)

- Commercially available lingual orthodontic STB bracket (ORMCO) with 018X.018"slot of right maxillary canine was selected.
 - Measurements of the brackets were made using a stereo-microscope accurate upto 0.01mm (Zoomer, SZ-790). The outer design of the labial brackets was scanned using a Breuckmann white light scanner.
4. After the modeling of the labial and lingual brackets, and tooth along with the supporting structures was done, the components were assembled together

Loading

A simulated retraction using active tieback of force 1.5 N (1N= 101.97grams) was loaded to the center of the crown through labial bracket and lingual bracket. The type of tooth movement is dictated by the M/F ratio at the bracket generated by the appliance. Typically, M/F ratios of approximately 5:1 to 7:1 give tipping, at M/F 10:1 accomplish translation and M/F near 12:1 give root movement. Initially on canine retraction through active tieback, M/F ratios are approximately 5:1 producing uncontrolled tipping. As the space closes and the elastic deactivates, the force level delivered by elastic decreases at a faster rate than the moments. This causes M/F ratio to increase. This ratio soon becomes 12:1, where root movement occurs. And this combined procedure leads to the bodily movement of the tooth with the M/F ratio of approximately 10:1. In this study, when 150 grams of retractive force was applied to the crown of the canine, the point of force application moves further away from the centre of resistance of the tooth in an occlusal direction.

Finite Element Assessment

The assessment of stress and strain in PDL and alveolar bone; and total deformation of tooth in this study was done under three conditions depending on the movement of tooth:

1. Initial 150 grams of retractive force application, resulting in the mesio-distal tipping of the crown.
2. Degradation of initial 150 grams of force and binding of wire in bracket resulting in 75 grams of couple, leading to mesio-distal uprighting of the root.
3. Combined force application to the tooth, resulting in the bodily movement of the tooth.
 - Stress distribution and its magnitude were then analyzed by ANSYS software, a 3D finite element analysis program. Assessment of the stress on the PDL and alveolar bone was performed by maximum and minimum principal stress, and used the total deformation value to assess the initial displacement of the teeth.
 - In this study, no statistical tools were applied, as the sample size was single and the standard deviation cannot be derived. Hence the direct comparison between the values for labial and lingual bracket system was done.

Results

The results obtained in the study are presented in this section. For the MBT labial bracket system along with the tooth assembly, a retractive force of 150 gms in .022X.028" slot was applied. Similarly for the STB lingual bracket system along with the tooth assembly, a retractive force of 150 gms in .018X.018" slot was applied.

I. Stress Produced In PDL & Alveolar Bone (Fig 12 -18)

(a) PDL

The stress pattern in the periodontal ligament was found to trace the path of the force application in all systems of force application. The tensile stress recorded in PDL with both labial and lingual retraction was evident in the apical region of the root but the value was lower in labial as compared to the lingual.

(b) Alveolar bone

The alveolar bone also experienced stresses along the same lines as that of the periodontal ligament in both the systems of force application. The tensile stress recorded in alveolar bone with both labial and lingual retraction was evident in the cervical region, but apical portion of bone also experienced stresses which gradually reduced towards apex. The values were lower in labial as compared to the lingual.

II Minimum Principal Stress Produced:

(a) PDL

The compressive stress recorded in PDL with both labial and lingual retraction was evident in apical region of root, but the values were lower in labial as compared to lingual.

(b) Alveolar bone

The compressive stress recorded in alveolar bone with both labial and lingual retraction was evident in cervical region, but apical portion of bone also experienced stresses which gradually reduced towards apex. The values were slightly lower in labial as compared to lingual.

Discussion

This study was designed to compare the biomechanical differences between the labial and lingual orthodontics involved in canine retraction using the **Finite Element method (FEM)**. FEM is a highly precise technique used to analyze structural stress. It provides three-dimensional model with a freedom to simulate orthodontic force system applied clinically and allows the analysis of the dentition to orthodontic load in three-dimensional spaces. Finite Element Analysis makes use of computer to solve large number of equation, which simulates the physical properties of the structure being analyzed.¹⁰

In the current study, **ANSYS software was preferred over others for the analysis**. As ANSYS can import computer assisted designing (CAD) data and also enables to build geometry with its "preprocessing" abilities. In the same preprocessor, finite element model which is required for computation is generated.

Here, in the present study, **.018" slot STB lingual brackets** have been used. They are narrower mesiodistally, which increases the interbracket distance and thus reduces both the force transmitted by the archwire and the resistance to sliding mechanics.⁴⁴ They are characterized by a friction free system and a low friction system which increases with arch-wire size. **Moran** calculated the overall ratio comparing anterior lingual to labial interbracket distance to be 1:1.47.¹³ This emphasized the necessity of using lighter wires in the lingual system due to the decreased interbracket distance.

In the current study, we have shown **the simulated individual (sequential) canine retraction using the sliding (friction method) mechanics** by an elastic component. Sliding mechanics was preferred over the closing loop mechanics (frictionless method) as it is less complicated, requires less wire bending and predictable retraction may be achieved. Generally closing loop mechanics is more complex due to the construction of the loop springs and their clinical management.

In this study, the **simulated canine retraction** with sliding mechanics was in consonance to the studies done by various authors. **Staggers JA** also discussed canine retraction as when retractive force was applied to the canine, the tooth

experienced a moment of force. This moment caused distal tipping of the crown. The distal crown moment contributes to the retraction that eventually caused binding of the archwire, which produced a moment of a couple that resulted in distal root torque.

In the current study, **a simulated 150 grams of force** was applied by an active tieback for canine retraction at the crown of the tooth with both labial and lingual bracket system. This force level was within the optimal biological limit. The initial force application should be light, because this produces desirable biologic effects. When an orthodontic force is applied to a tooth, **stresses are produced in the periodontal ligament (PDL) and the surrounding bone**. Proffit pointed out that the change of the PDL is the first and key biomechanical phenomenon of tooth movement. Resorption of the alveolar bone occurs in the region of compressive stress, whereas apposition occurs in a region of tensile region. The present study was undertaken mainly to compare the stress produced with the labial and lingual bracket system in the PDL and alveolar bone on canine retraction.

Interpretation of the results of the present study showed that the stress pattern in PDL was found to trace the path of the force application. In labial bracket setup on application of 150grams of retractive force, the maximum principal stress (tensile stress) in PDL was highest on the mesial root surface of the canine and highest minimum principal stress (compressive stress) in PDL was observed on the distal root surface. In the current study, on force degradation due to the deformation of elastic component, major drop by 50% in the stresses and strain was recorded in both the PDL and alveolar bone. This can most likely be attributed to the binding of the wire in the slot, resulting in lower bending stress.

Summary & Conclusion

Within the limitations of our study, we summarize and conclude the following:

- On retraction, the high stress was produced with the Labial system in the PDL and alveolar bone that gradually reduced on force degradation. On combined force application slight increase in stress was noticed.
- On retraction, the higher stress was produced with the Lingual system in the PDL and alveolar bone that gradually reduced on force degradation. On combined force application slight increase in stress was noticed.
- On retraction, Lingual system showed high total deformation in the tooth on comparison with Labial system. With force degradation, greater fall in total deformation was recorded with Lingual system.
- In conclusion, Lingual system has different biomechanical effects than the Labial system in terms of stress, strain and total deformation on the PDL, alveolar bone and tooth. Therefore decreased horizontal retraction forces should be used to achieve desired orthodontic results and subsequent stress distributions in the periodontal ligament and alveolar bone.

Bibliography

1. Cattaneo PM, Dalstra M, Melsen B. Strains in periodontal ligament and alveolar bone associated with orthodontic tooth movement analyzed by finite element. *Orthod Craniofac Res.* 2009;12 (2):120-28.
2. Cattaneo PM, Dalstra M, Melsen B. The finite element method: a tool to study orthodontic tooth movement. *J Dent Res.* 2005;84 (5):428-33.
3. Farah JW, Craig RG, Sikarskie DL. Photoelastic and finite element stress analysis of a restored axisymmetric first molar. *J Biomech.* 1973; 60:511-20.
4. Fuck LM, Wiechmann D, Drescher D. Comparison of the initial orthodontic force systems produced by a new lingual bracket system and a straight-wire appliance. *J Orofac Orthop.* 2005;66(5):363-76
5. Grauer D. Accuracy in tooth positioning with a fully customized lingual orthodontic appliance. *Am J Orthod Dentofacial Orthop.* 2011; 140:433-43
6. Jeon PD, Turley PK, Moon HB, Ting K. Analysis of stress in the periodontium of the maxillary first molar with a three-dimensional finite element model. *Am J Orthod Dentofacial Orthoped.* 1999; 115:267-74.
7. Jones ML, Hickman J, Middleton J, Knox J, Volp C. A validated finite element method to study the orthodontic tooth movement in the human subject. *Journal of Orthodontics.*2001; 28:29-38.
8. Kazuo Tanne, Mamoru Sakuda, Charles J. Burstone. Three-dimensional finite element analysis for stress in the periodontal tissue by orthodontic forces. *Am J Orthod Dentofacial Orthop.* 1987; 92: 499 – 505
9. Kim L. Andersen, Erik H. Pedersen, M. Birte. Material parameters and stress profiles within the periodontal ligament. *Am J Orthod Dentofacial Orthoped.*1991; 99: 427-40.
10. Mahler DB, Peyton FA. Photoelasticity as a research technique for analyzing stresses in dental structures. *J Dent Res.* 1955; 34:831-38.
11. Noble J, Hechter FJ, Karaiskos NE, Lekic N, Wiltshire WA. Future practice plans of orthodontic residents in the United States. *Am J Orthod Dentofacial Orthop.* 2009;135(3):357-60.
12. Nuno Ferreira Rilo, Edson Antonio Ferreira, Carlos Alberto Cimini Junior, Estevam Barbosa de Las Casas. The use of finite element analysis to improve the studies reliability of mechanical behavior of orthodontic wires. 3rd International Conference on Integrity, Reliability and Failure, Porto/Portugal, July 2009; 20-24
13. Peter D. Jeon, Patrick K. Turley, Hong B. Moon, Kang Ting. Analysis of stress in the periodontium of the maxillary first molar with a three-dimensional finite element model. *Am J Orthod Dentofacial Orthoped.* 1999; 115:267-74.
14. Rudolph DJ, Willes MG, Sameshima GT. A finite element model of apical force distribution from orthodontic tooth movement. *Angle Orthod.* 2001;71:127-31.
15. Russell JS. Aesthetic orthodontic brackets. *J Orthod.* 2005;32(2):146-63.
16. Shum Lily M-Y, Ricky Wing-Kit W, Urban H. Lingual orthodontics. *Rev Hong Kong Dent J.* 2004; 1:13-20
17. Silvia Geron, Rafi Romano, Tamar Brosh. Vertical forces in labial and lingual orthodontics applied on maxillary incisors- A theoretical approach. *Angle Orthod.* 2004;74:195-201
18. Tirupathi R. Chandrupatla. *Finite Element Analysis for Engineering and Technology.* Universities Press (India) Private Limited; 2004:1-9.

19. Wiechmann D, Rummel V, Thalheim A, Simon VS, Wiechmann L: Customized bracket and archwires for lingual orthodontic treatment. Am J Orthod Dentofacial Orthop 2001; 124:593-99
20. Wiechmann D. A new bracket system for lingual orthodontic treatment. Part 2: First clinical experiences and further development. J Orofac Orthop. 2003;64(5):372-88.



Fig:1 .022" MBT Labial bracket system

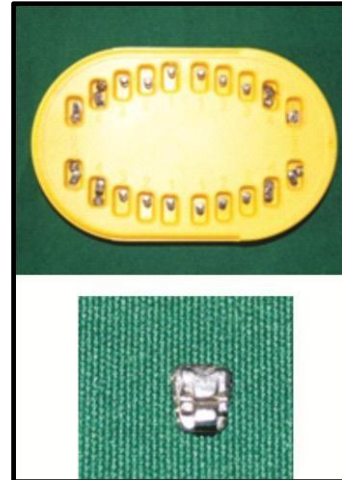


Fig:2 .018" STB Lingual bracket system



Fig: 3. Computational softwares

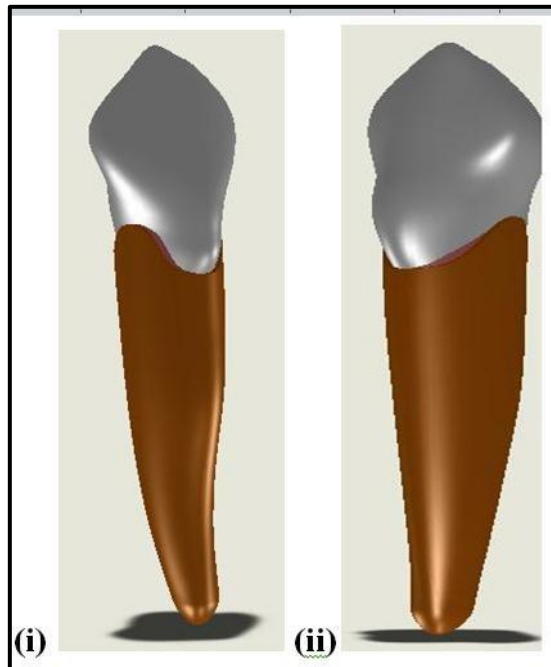


Fig 4: Right maxillary canine (i) labial view; (ii) lingual view

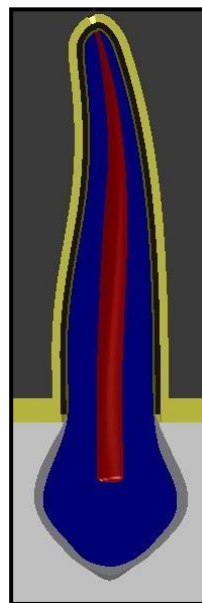


Fig 5 Cross-Section: Right maxillary canine- Dentine, Cementum,

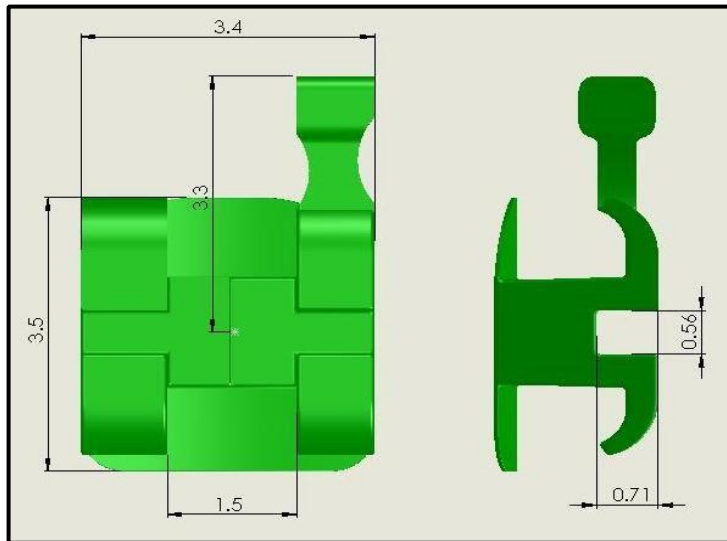
PDL and Alveolar bone

Fig 6 3D model: Labial (MBT) bracket with measurements

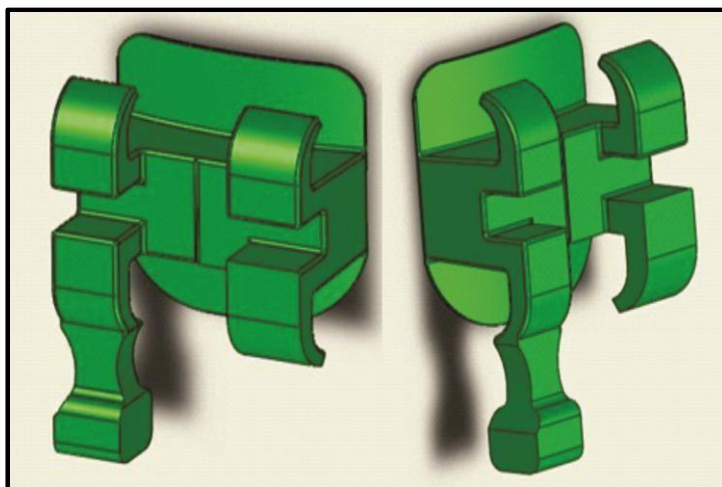


Fig 7 3D model: Labial (MBT) bracket

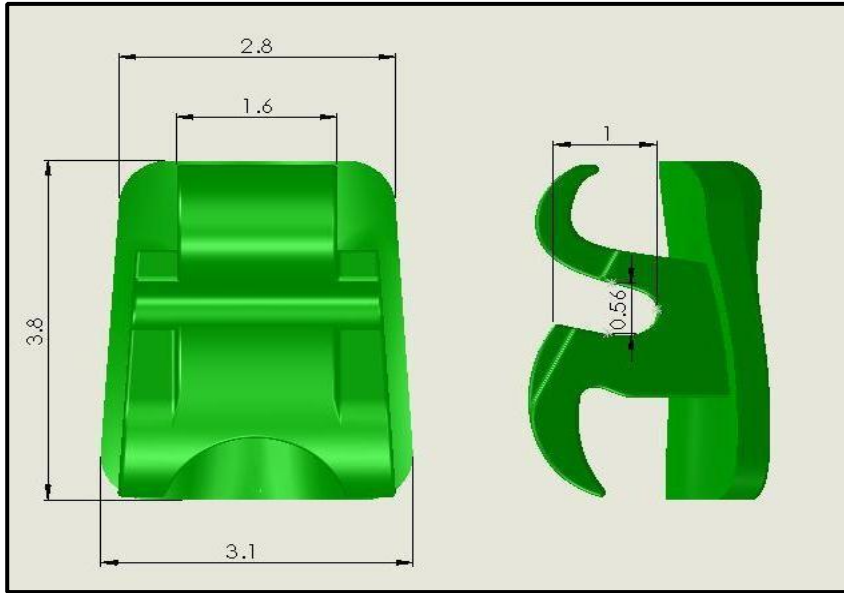


Fig 8 3D model: Lingual (STB) bracket with measurements

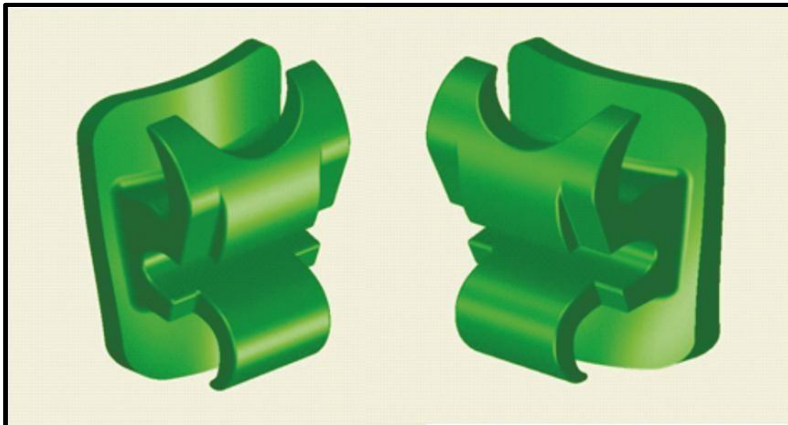


Fig 9 3D model: Lingual (STB) bracket

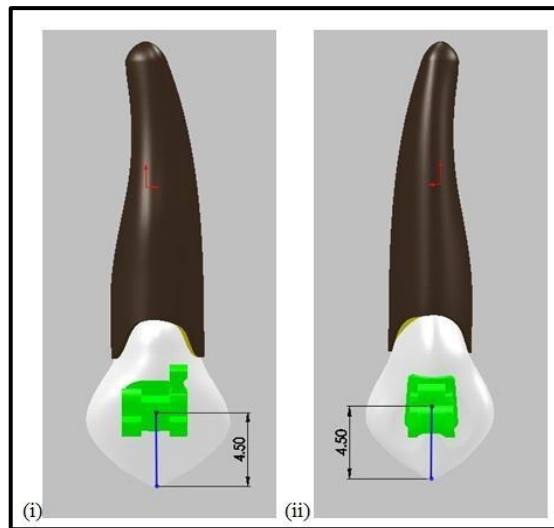


Fig 10 Assembly of (i) Labial MBT and (ii) Lingual STB bracket with tooth and measurements

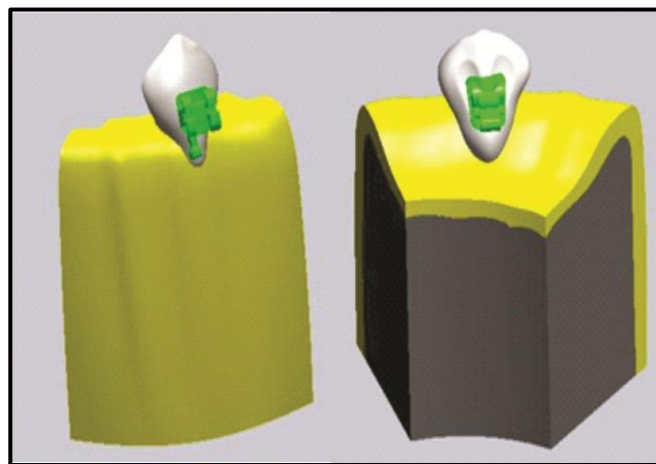


Fig 11 3D model: Right maxillary canine with brackets in cut section

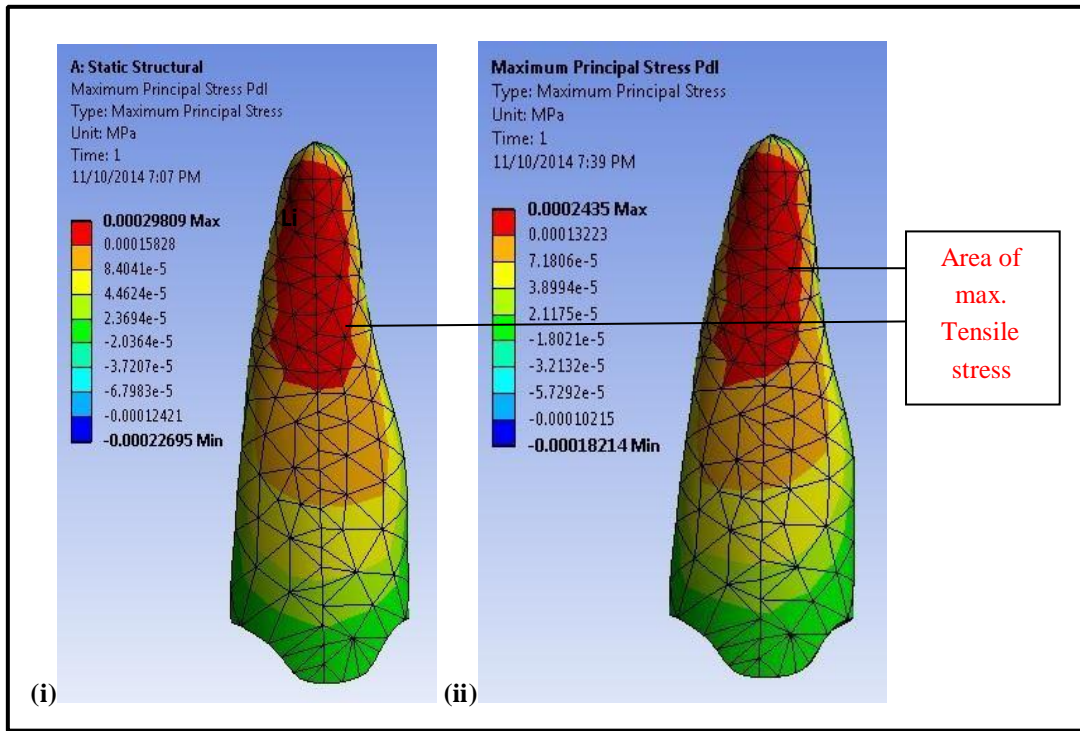


Fig 12 Maximum principal stresses produced in PDL on application of 150grams of retractive force with (i) labial and (ii) lingual mechanics

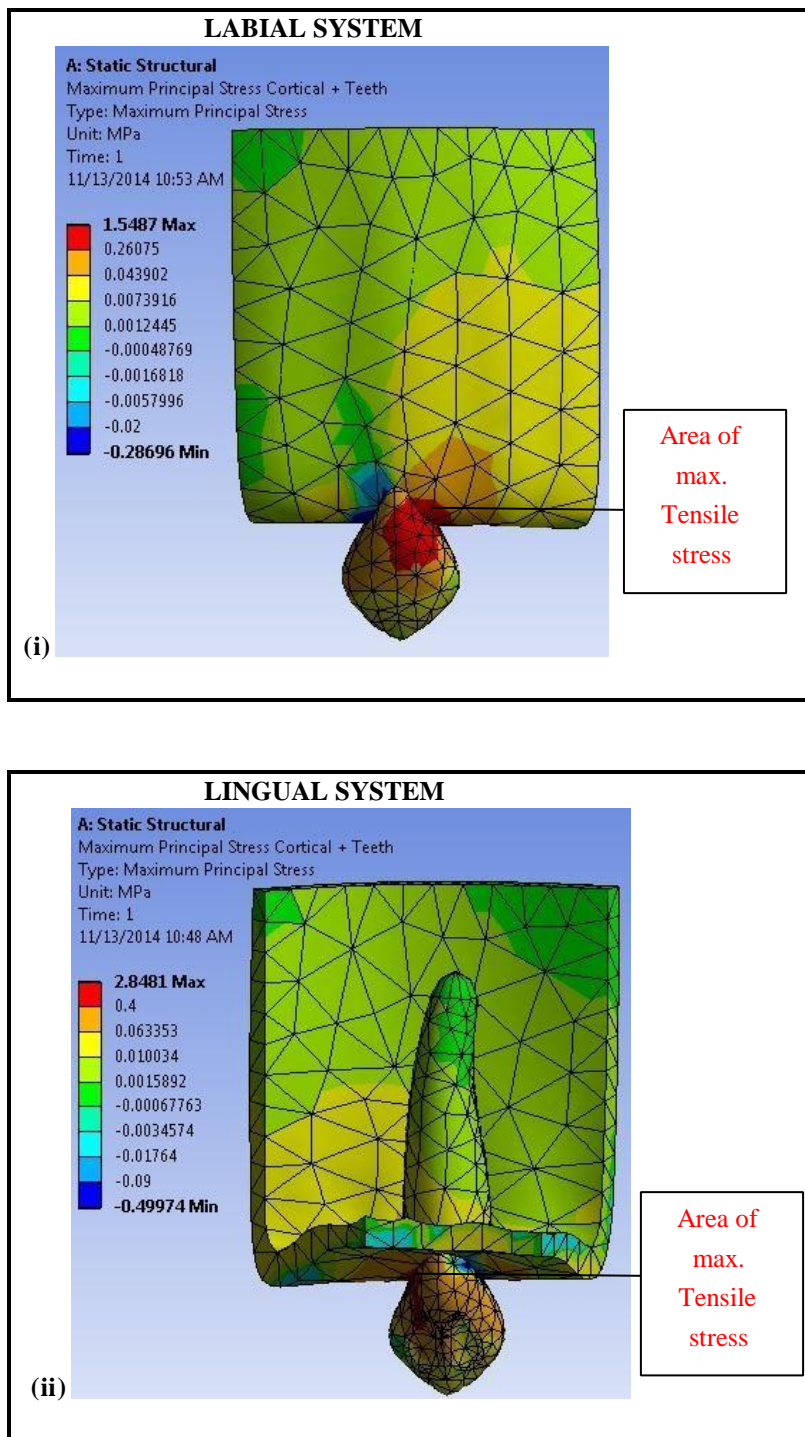


Fig 13 Maximum principal stresses produced in Alveolar bone on application of 150grams of retractive force with (i) labial and (ii) lingual mechanics

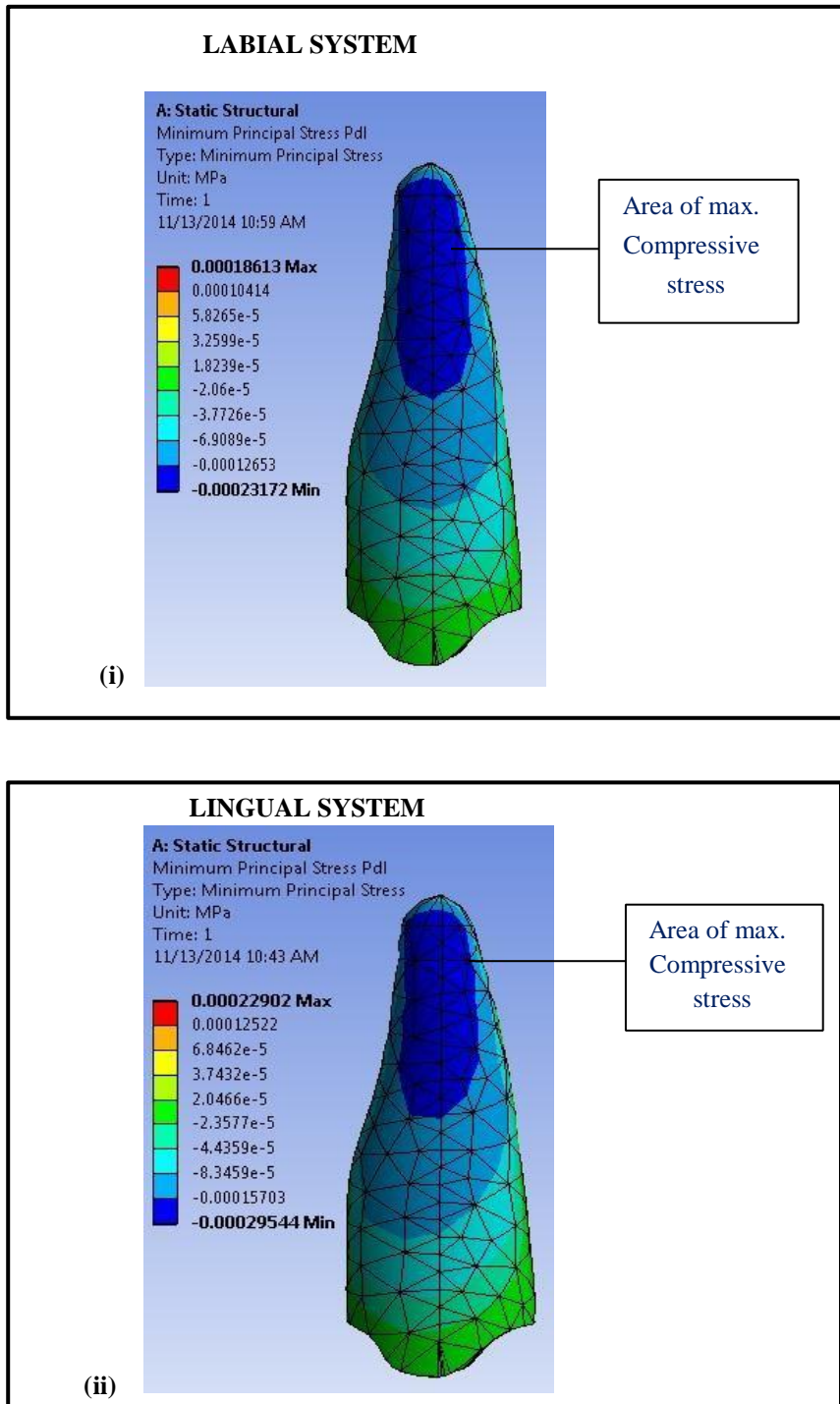


Fig 14 Minimum principal stresses produced in PDL on application of 150grams of retractive force with (i) labialand (ii) lingualmechanics

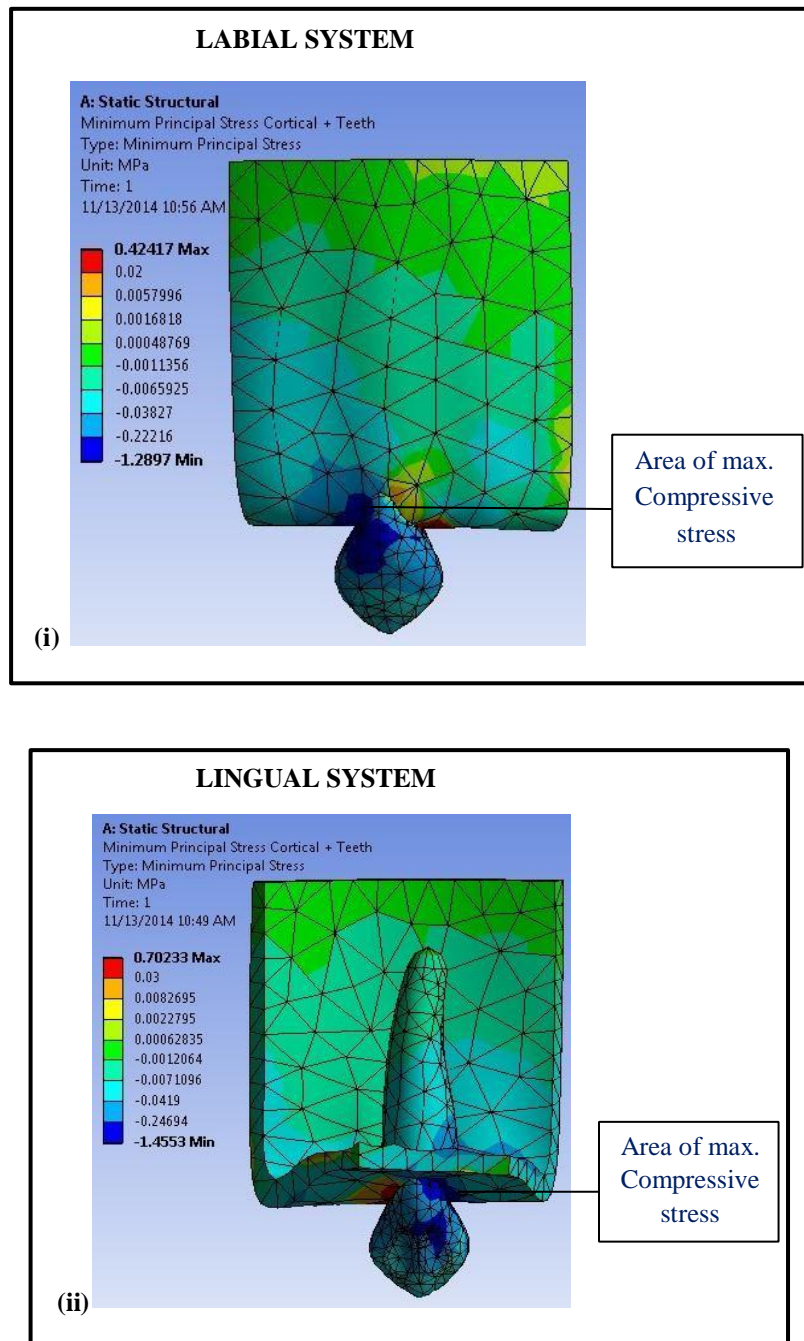


Fig 15 Minimum principal stresses produced in Alveolar bone on application of 150grams of retractive force with (i) labial and (ii) lingual mechanics

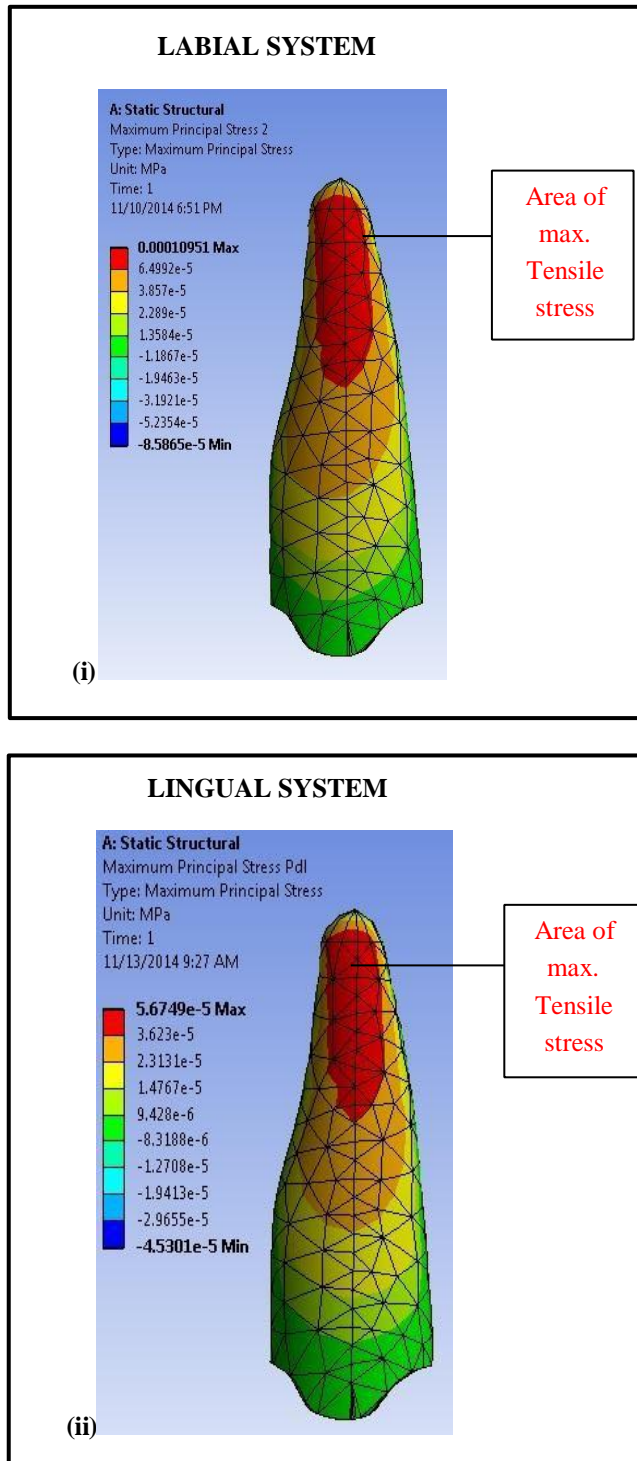


Fig 16 Maximum principal stresses produced in PDL on force degradation with (i) labial and (ii) lingual mechanics

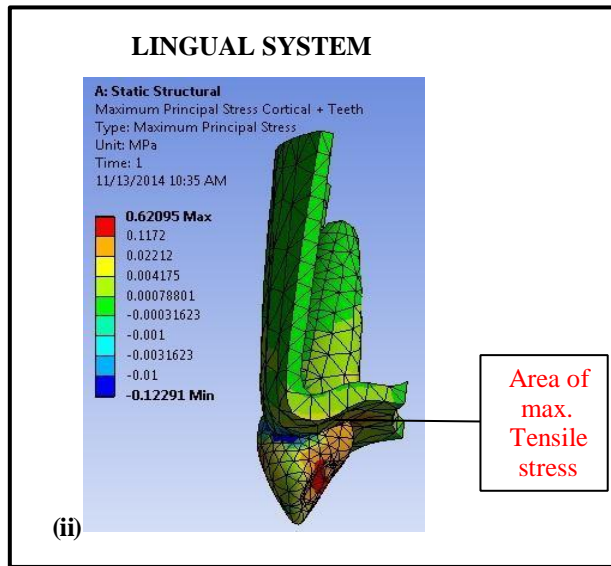
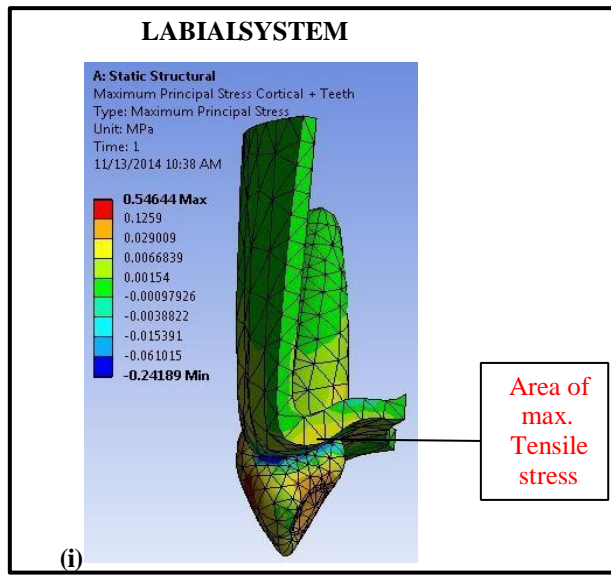


Fig 17 Maximum principal stresses produced in Alveolar bone on force degradation with (i) labial and (ii) lingual mechanics

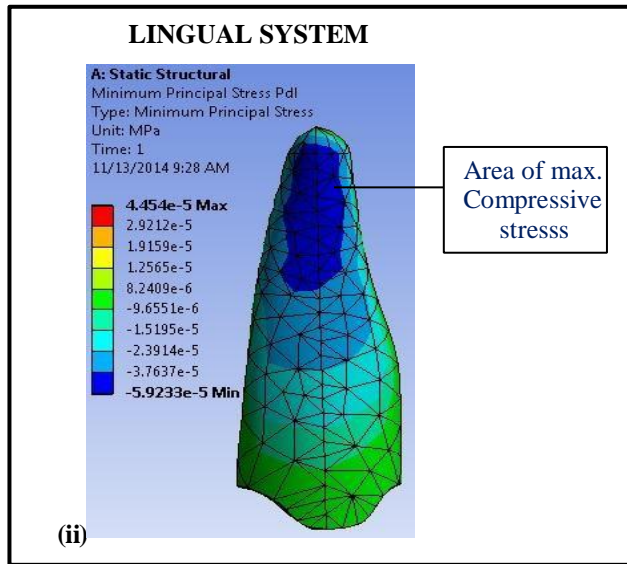
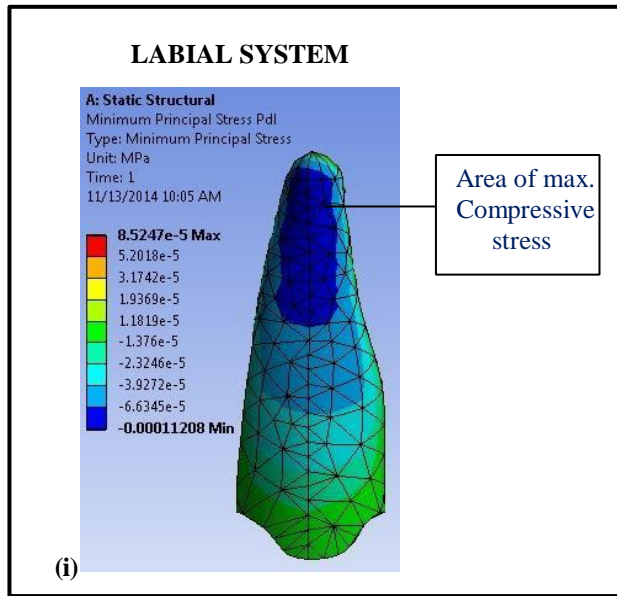


Fig 18 Minimum principal stresses produced in PDL on force degradation with (i) labial and (ii) lingual mechanics