

How to Cite:

Srivastava, K. N., & Raj, R. (2022). Aerodynamic study of tall buildings under wind load. *International Journal of Health Sciences*, 6(S3), 2620–2641.
<https://doi.org/10.53730/ijhs.v6nS3.6142>

Aerodynamic study of tall buildings under wind load

Kunwar Navodit Srivastava

Department of Civil Engineering, Delhi Technological University, Delhi, 110042, India

Ritu Raj

Department of Civil Engineering, Delhi Technological University, Delhi, 110042, India

Abstract--In Design of high-rise structures, Wind is considered as one of the important horizontal forces that have significant impact on the response of building. Due to rise in population, the demand for tall buildings is increasing day by day. Wind Load on such structures are calculated using pressure coefficients and force coefficients which are available in various international codes and standards. However, these international codes and standards give information about regular shape buildings such as square, rectangle, circular or octagonal. With the technological advancement, composite plan shape buildings such as square and circular, circular and hexagonal and square and octagonal etc. have been considered by many architects keeping in view of aesthetics of Building. The wind flow around a tall building with composite plan shapes having different height ratio variation differs from what we get in regular shape analysis. Since, data is not available regarding such buildings, the need to carry wind tunnel testing or CFD become important for analyzing wind effect on such buildings. CFD (Computation Fluid Dynamics) for determining wind responses is becoming immensely popular. It has expanded as a tool to replace wind tunnel testing as it is quicker, less expansive and give more information and control to designers. In the present research study, two building plan shape triangle and circle has been considered with different height ratio. The building selected to carry out the numerical analysis are uniform and composite plan tall buildings. The length of equilateral triangle is taken as 40m and height being 200m. For composite plan shape building only height ratio is changed keeping the same dimensions. The prototype building is considered to be located in terrain category 2 as per IS-875 Part 3. Assumption is made that the variation for wind speed with height follows the power law with power law coefficient taken as .177. CFD analysis is carried

out in ANSYS CFX taking 1:200 scaled down model of tall buildings. In total, 5 models have been considered and pressure is evaluated taking various points on the building. Each model is analyzed for different angle of wind incidence namely 0, 60, and 120 degrees. The result obtained for the uniform shape cross section building has been compared with the wind tunnel testing results available in various literatures.

Keywords--tall building, CFD, wind effect, wind angle, force coefficient, pressure coefficient.

Introduction

Tall Buildings have always fascinated humans having unique appeal and pride associated with them. Due to increasing population and scarcity of land the demand for Tall Buildings have increased day by day. With the development of new better construction techniques, better materials and structural systems, these buildings have proven to be the safe and economical structural solution to problem of spacious designs. In design of tall structures, wind loading is one of the prime important lateral loads that needs to be considered while designing. In general, occupant comfort needs to be considered along with structural safety. Wind is a time varying force having two components, a mean and a fluctuating component. Wind is a complicated phenomenon having eddies of varied size add rotating properties. Due to these eddies wind is turbulent and gusty in nature. Wind Loading initially was viewed as estimating the dynamic pressure of wind at the structure and then just multiply it by some Shape factor and area of a structure to obtain the wind force.

However later it was realized that wind dynamic in nature and dynamic responses such as galloping, flutter, vortex excitement, ovalling etc. need to be examined too. The shape of buildings is a well-known subject in aerodynamics optimization that has a significant impact on the behavior of high structures under wind loads. Wind response can be reduced by optimizing the geometry of supertall structures for aerodynamics during the design stage. Wind is a phenomenon in which the motion of individual particles is so unpredictable that statistical distributions of velocity rather than simple averages must be considered. Although each has its own local impact, the total wind force is equal to the sum of windward pressure and leeward suction. In order to get complete wind analysis, one need to determine the wind climate, influence of terrain and topography, aerodynamic shape of a structure and dynamic effects. Various international codes and standards such as ASCE 7-10: Minimum design loads for buildings and other structures, IS-875 Part 3 : Code of practice for design loads (other than earthquake) for buildings and structures), BS 6399-2:1997 loading for buildings code of practice for Wind loads British standards, EN 1991-1-4: Eurocode : Actions on Structure Part 1-4: General Actions-Wind Actions, 2010 estimates the pressure coefficients and force coefficients which are used for computing wind loads on buildings subjected to windloads.

Very Limited Information for uniform plan shaped buildings with different aspect ratio are available in these standards. The Indian code suggests pressure coefficients for different plan shape like square, rectangle etc. at 0-degree and 90-degree angle of wind incidence. The wind pressure of tall building not only influenced by building geometry and wind incidence but also depend upon height ratio between the plan shapes. However, these codes do not provide information regarding wind load acting on composite plan shaped buildings. Also, available information does not include wind pressure coefficient (C_p) or wind force coefficient (C_f) for the buildings where cross-sectional shape change with height. For such buildings wind tunnel testing have been proven to be the efficient and practical approach to study the response of buildings and structures under wind load. Recent Studies have also shown the use of CFD to carry out investigation for wind load pressure distribution and computation of pressure and force coefficients.

CFD (Computational fluid dynamics)

Computational fluid dynamics involves numerical approach and algorithms to solve and analyze problems that involves fluid flow. CFD analysis is widely employed in aerodynamics and hydrodynamics where pressure and velocities are the parameters. CFD analysis can save a lot of time and are cheaper as compared to conventional testing. All of the relevant parameters may be analyzed and monitored at the same time in CFD, with great time and spatial resolution. Because CFD analysis approximates a genuine physical solution, it cannot totally replace actual testing. The steps of CFD analysis include the following:

- Pre-processing
- Solving
- Post processing

Compared to wind tunnel testing, CFD has the following advantages:

- Comprehensive domain analysis
- Simple alternative analysis
- Improved visualisation of outcomes
- Cost-effective

CFD Validation

The validity of the ANSYS CFX software is validated before beginning the numerical study of the building. For this purpose, a square plan shaped building with dimensions of 150 mm \times 150 mm and a height of 500 mm (i.e., aspect ratio 1:5) is investigated using the k-model with ANSYS CFX in the domain under uniform wind flow.

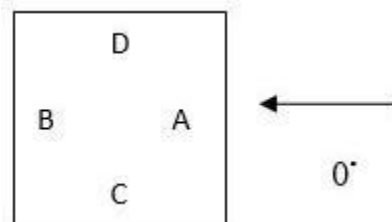

Figure 1. Different faces of the model with direction of wind
 At the inlet, a uniform wind flow of 10 m/s is given. As previously stated, the domain is built according to Revuz et al (2010). The ANSYS CFX programme determines the face average values of coefficient of pressure, which are then compared to wind action codes from various regions.

Table 1
 Comparison of face average values of coefficients of pressure

Wind loading code	Face- A	Face-B	Face-C	Face-D
By ANSYS CFX	0.9	-0.46	-0.67	-0.68
ASCE 7-10	0.8	-0.5	-0.7	-0.7
AS/NZS-1170.2(2002)	0.8	-0.5	-0.65	-0.65
IS: 875 (part3) (2015)	0.8	-0.25	-0.8	-0.8

Model scale

In this study, two different composite building plan shapes, triangle and circle are considered with different height ratios. The sides of triangle and total height of buildings are 40m and 100m respectively. The following dimensions are considered for all models with only height ratio changed. The prototype building has been considered to be situated at in Terrain Category- The free mean wind velocity is taken as 10m/s and each model is studied at various wind incidence angle of 0°, 60°, 120°, 180°. The wind profile boundary layer is governed by power law equation with power law index coefficient as 0.147.

Parameter	Prototype Dimension(m)	ANSYS Model Dimension(mm)	of Mod
Length	40	200	e11:200
Height	100	500	

The following geometrical parameters are considered in this study,

- Wind Incidence Angle (0°, 60°, 120°, 180°)
- Cross section combination of Triangle and Circle along height.
- Height of Building (50% Triangle & 50% Circle)

This study also has been validated with wind pressure of an isolated square plan shape, tall building using CFD simulation and compared it with wind effects of conventional plan shape building given in Indian code IS: 875 (Part- 3), 2015.

Methodology

Design wind pressure

As per IS-875 Part 3,

[Design Velocity] = $V_b * K_1 * K_2 * K_3 * K_4$ Where, V_b =Basic Wind velocity
 K_1 = Probability Factor/Risk Coefficient K_2 =Terrain and Height Factor
 K_3 =Topography Factor

K4=Importance factor of the cyclonic region Design wind pressure is given as:

$$Pd=0.6 [Vz]^2$$

The mean pressure coefficient 'Cp mean' is calculated from the equation given below:

$$C_p \text{ mean} = \frac{(p - p_o)}{\frac{1}{2} \rho U_H^2}$$

where p is the pressure at point on surface,
 p_o is the reference height static pressure,
 ρ is the air density
 U_H is mean wind velocity at the building reference height.

Models

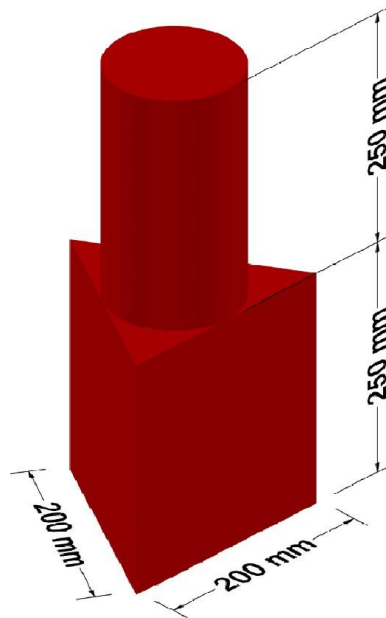

Figure 2. Model 2 50% Triangle 50% Circle

Domain

In case of high-rise buildings, domain size is mainly governed by height of the building such that a large number of cell count could be formed and out of them, many being used up in the region far away from wake region. Domain size selected in modeling is defined as per Frank et al (2004), The inlet and outlet distance of the domain from the building position is taken as 5H and 15H, respectively. The

side aspect and top clearance are also taken as $5H$, where H is the height of the building. The domain configurations are depicted in Fig.

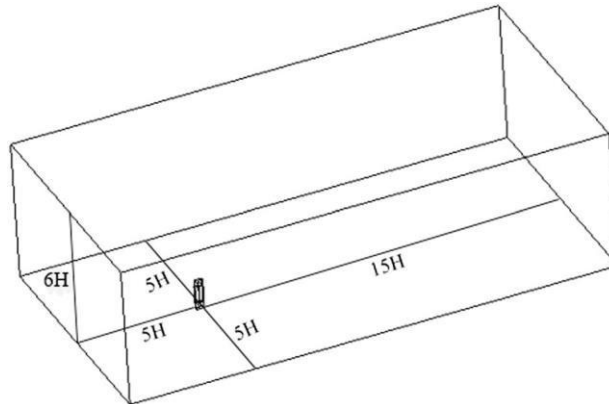

Fig 2. Domain used for the study

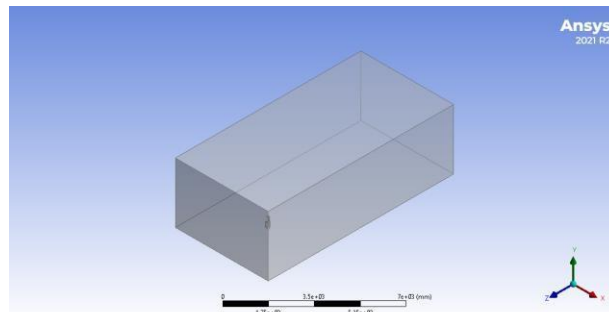

Fig 3. Domain

Meshing

Meshing is an integral part of engineering simulation process where complex geometries are divided to simple elements that can be used as discrete local approximations of larger domain. Meshing influences the accuracy, convergence and speed of the simulation. Finer the mesh, better the accuracy. Types of Mesh:

- Tetrahedron Meshing
- Pyramid Meshing
- Hexahedron Meshing
- Polyhedron Meshing
- Prism Meshing

The meshing in domain is done by tetrahedral mesh elements. Meshing near the buildings are made comparatively finer for enhancing the accuracy of results. The velocity at the inlet is taken as 10 m/s. No slip condition is defined for side walls and ground.

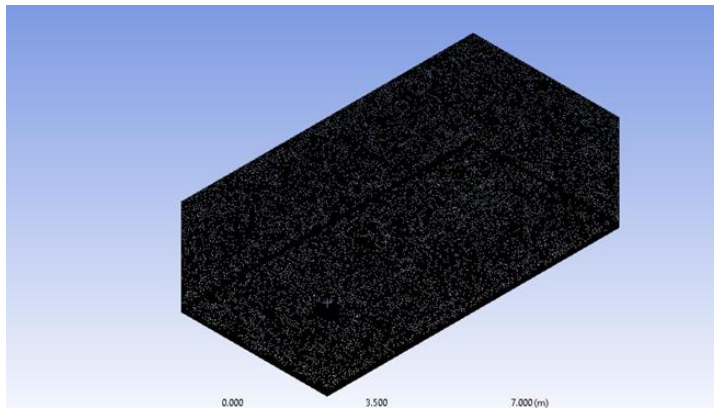

Fig 4. Mesh pattern

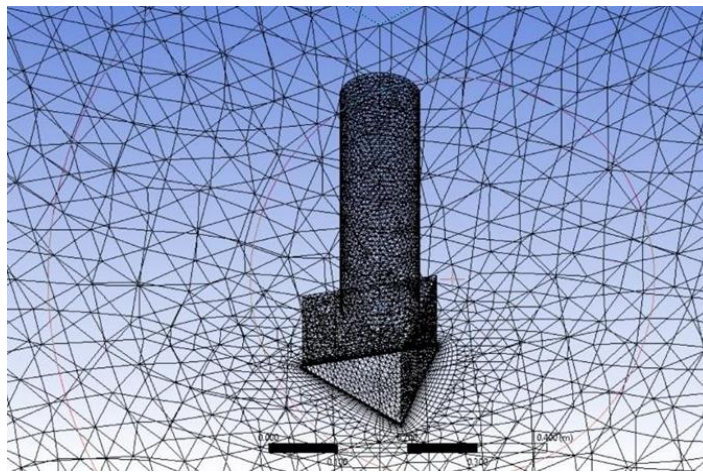

Fig 5. Mesh pattern around the building

Mean wind profile with height

Due to the roughness of earth surface, there acts a drag force on wind flow near the ground. This effect gradually decreases as the height increases and at a certain gradient level (around 400m), this drag-force becomes negligible. The degree of surface roughness and drag caused by surrounding projections that oppose wind flow determine the vertical profile of wind speed. Gradient height is the height at which the drag effects disappear, while gradient velocity is the corresponding velocity. The height up-to which wind speed is influenced by topography is called atmospheric boundary layer.

Power law

As per Power Law, the wind speed profile within the atmospheric boundary layer is given by:

$$= \left[\left(\frac{Z}{Z_0} \right)^{\frac{1}{n}} \right]$$

V_0
 Z_0
 α

Where, V = velocity of wind at height Z

V_0 = gradient velocity of wind at reference height Z_0
 Z = height above ground
 Z_0 = Nominal height of Boundary layer (also called gradient height)
 α = power law coefficient.

Logarithmic law

$$u = \frac{u_*}{k} \ln \frac{Z}{Z_0}$$

where u is the wind speed at height Z above ground, k is the von Karman constant equal to 0.4 (approximately) and Z_0 is the ground roughness. u_* is shear velocity which is defined as:

$$u_* = \sqrt{\frac{r_0}{\rho}}$$

where r_0 is the stress of wind at ground level and ρ is the air density.

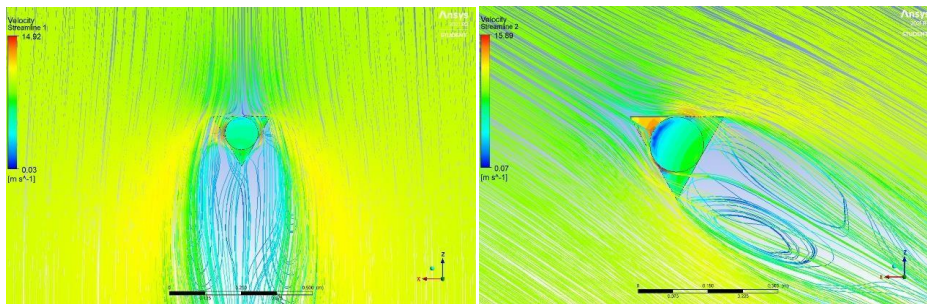

0° Wind Angle

60° Wind Angle

Fig 6. Wind flow pattern around the building for various wind angles

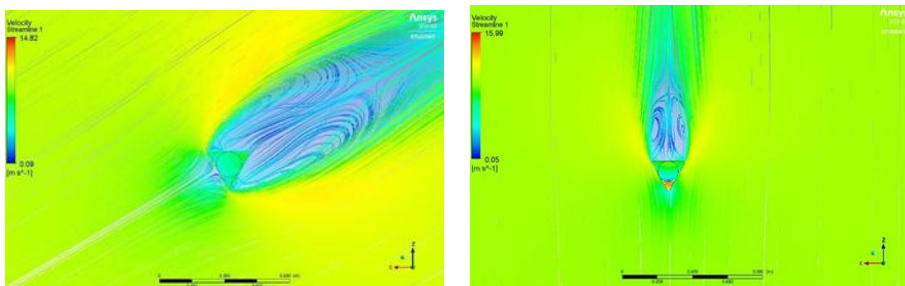

120° Wind Angle

180° Wind Angle

Pressure distribution

The pressure variation at various faces of Buildings are as shown using contour plots.

Model- 1 (250 triangle 250 circle)

- Figures 5-1 to 5-28 exhibit the pressure distribution on different faces at varying angles of incidence.
- Initially, at 0 degree of incidence face A shows a positive pressure being the windward face of the triangular building whereas face B and C depicts a negative pressure distribution being the leeward and side wall face of the building.
- Similarly, at 0 degree of incidence face A shows a positive pressure being the windward face of the circular building whereas face B, C And D depicts a negative pressure distribution being the leeward and side wall face of the building.
- As the angle of incidence changes to the pressure distribution changes and so the pressure coefficient.
- For 60° and 120° angle of incidence, positive pressure distribution at face A become slightly less compared to what in case of 0° along with suction pressure increase at face C in triangular building and face D in circular and a comparable change can be viewed from the pressure coefficient data so obtained as a result.
- For 180° angle of incidence, face C in triangular building and face D in circular building become windward and similar contour plot pattern as of face A when angle of attack was 0° can be seen.

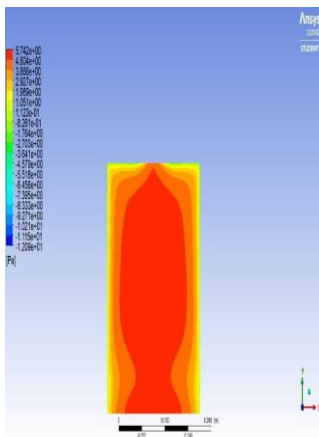

Triangle Face A

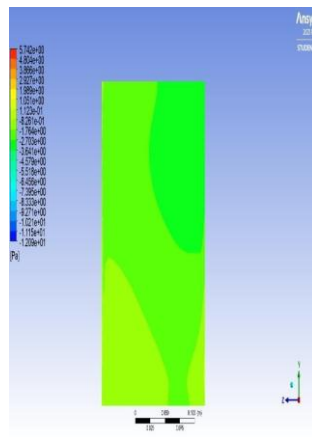

Triangle Face B

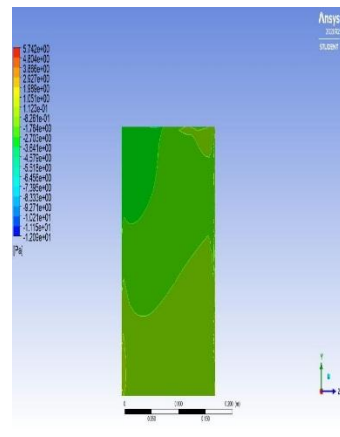

Triangle Face C

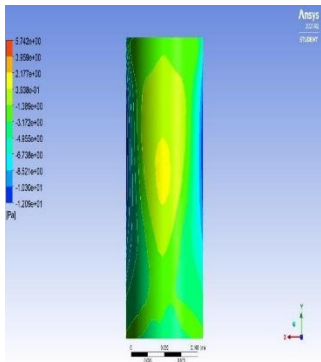

Circle Face A

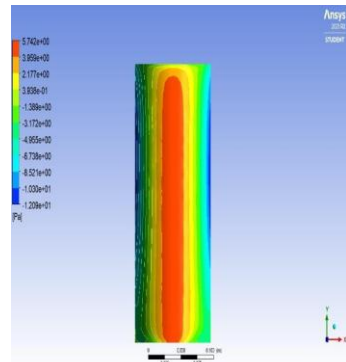

Circle Face B

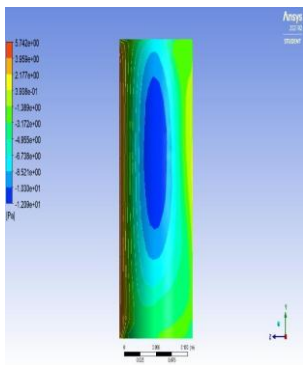

Circle Face C

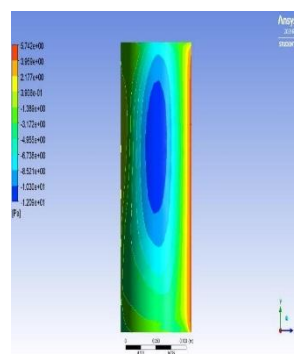

Circle Face D

Sixty-degree contour plot

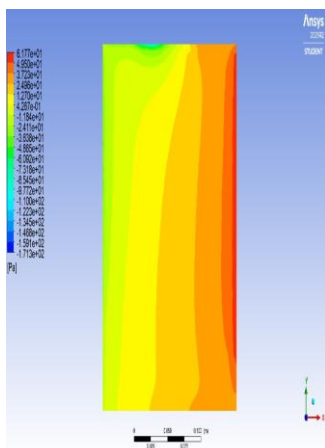

Triangle Face A

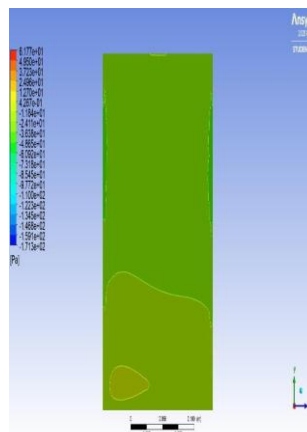

Triangle Face B

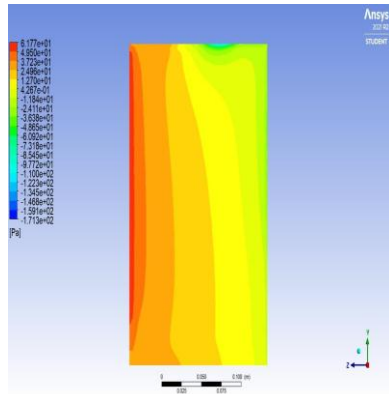

Triangle Face C

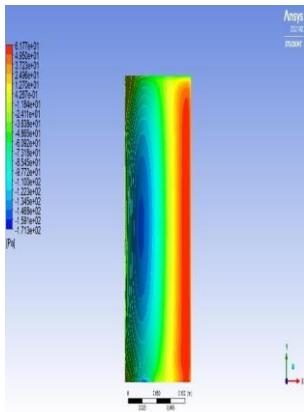

Circle Face A

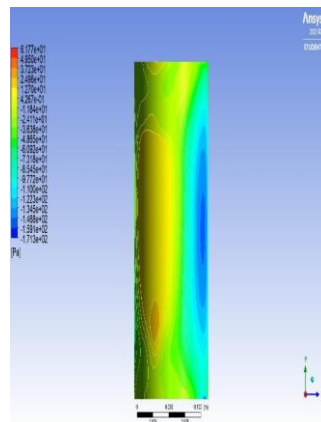

Circle Face B

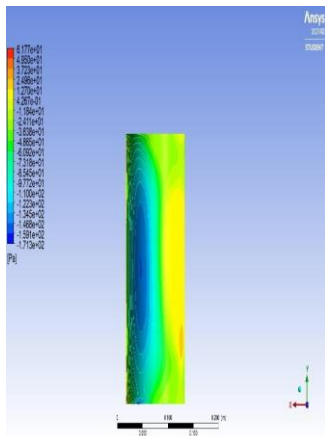

Circle Face C

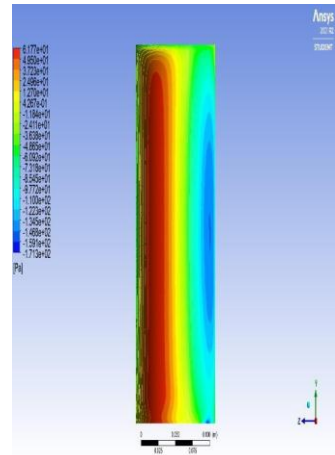

Circle Face D

One twenty contour plot

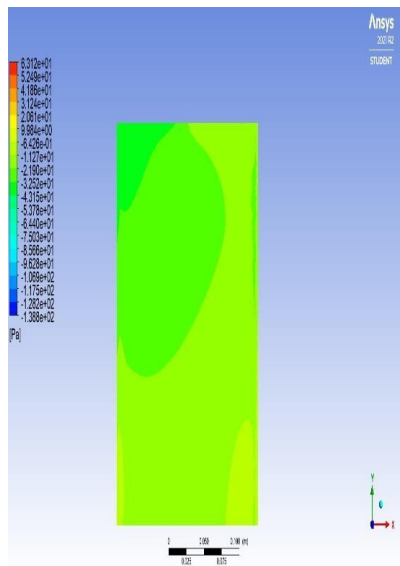

Triangle Face A

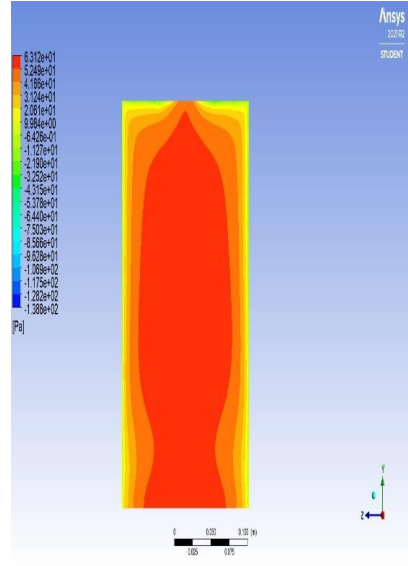

Triangle Face B

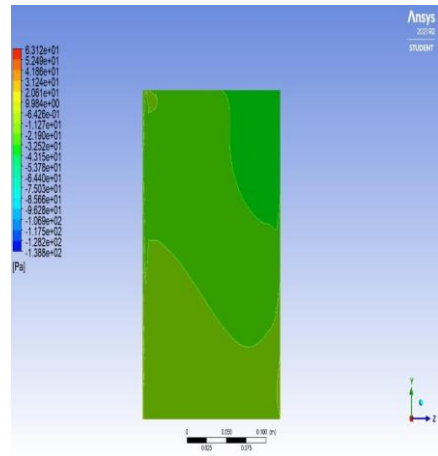

Triangle Face C

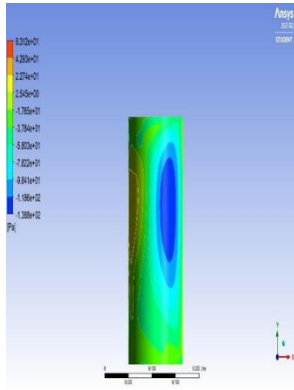

Circle Face A

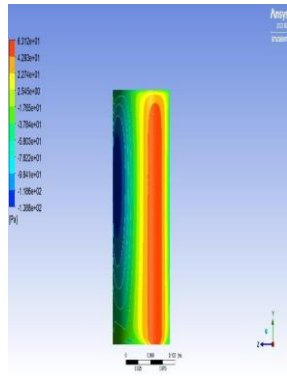

Circle Face B

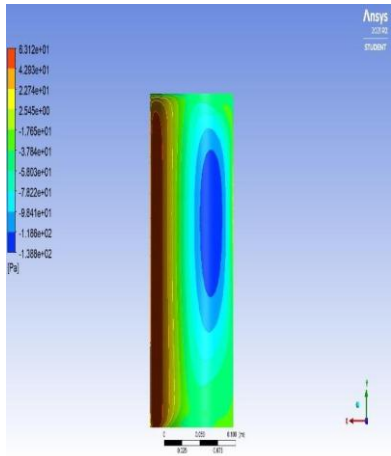

Circle Face C

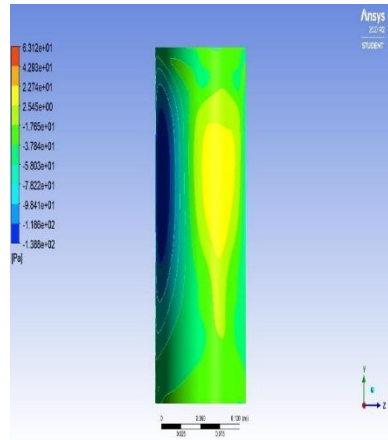

Circle Face D

One eighty contour plot

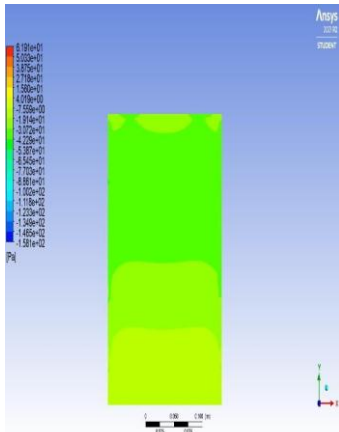

Triangle Face A

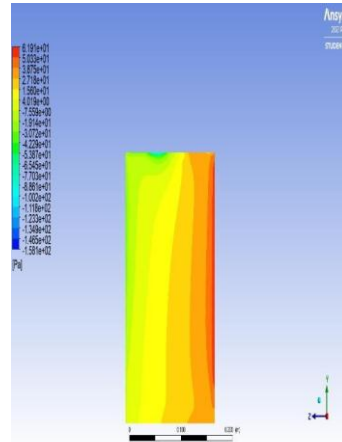

Triangle Face B

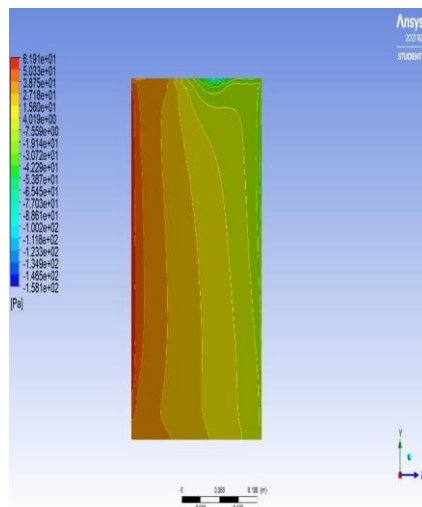

Triangle Face C

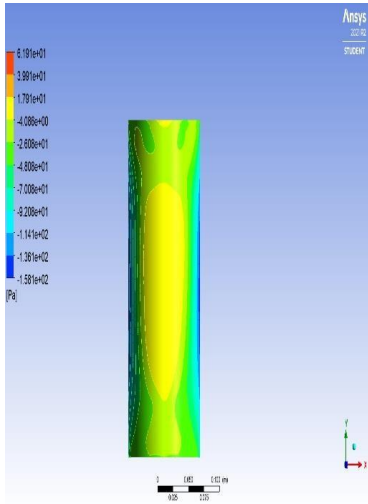

Circle Face A

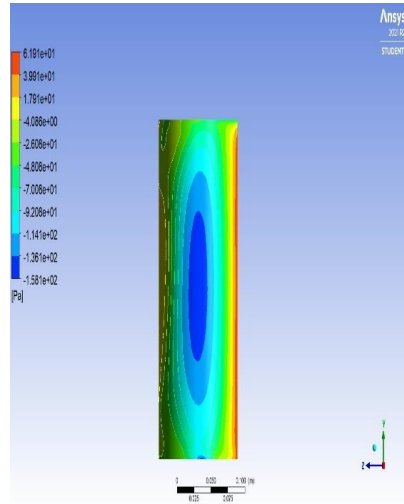

Circle Face B

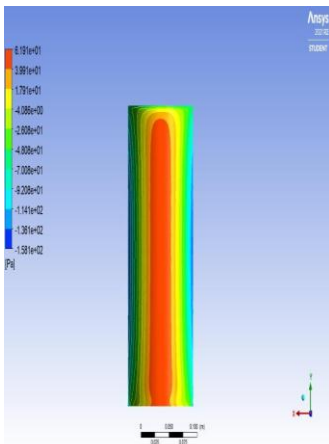

Circle Face C

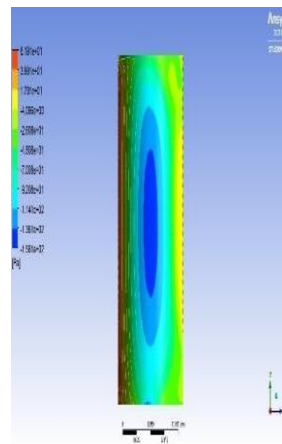

Circle Face D

Model 2 (250 Triangle 250 Circle)

- The C_p Variation along the centerline for all the faces at different angle of incidences are depicted in fig 5-29 to 5-35.
- For faces A of the triangular building the mean face average values of C_p at $0^\circ, 60^\circ, 120^\circ$ and 180° angle of attack are +.78, -0.1, -.0.2, and -0.4 respectively.
- For faces B of the triangular building the mean face average values of C_p at $0^\circ, 60^\circ, 120^\circ$ and 180° angle of attack are -.78, -.74, -.80, and -.72 respectively.
- For faces C of the triangular building the mean face average values of C_p at $0^\circ, 60^\circ, 120^\circ$ and 180° angle of attack are -.48, +0.9, +.82, and -0.49

respectively.

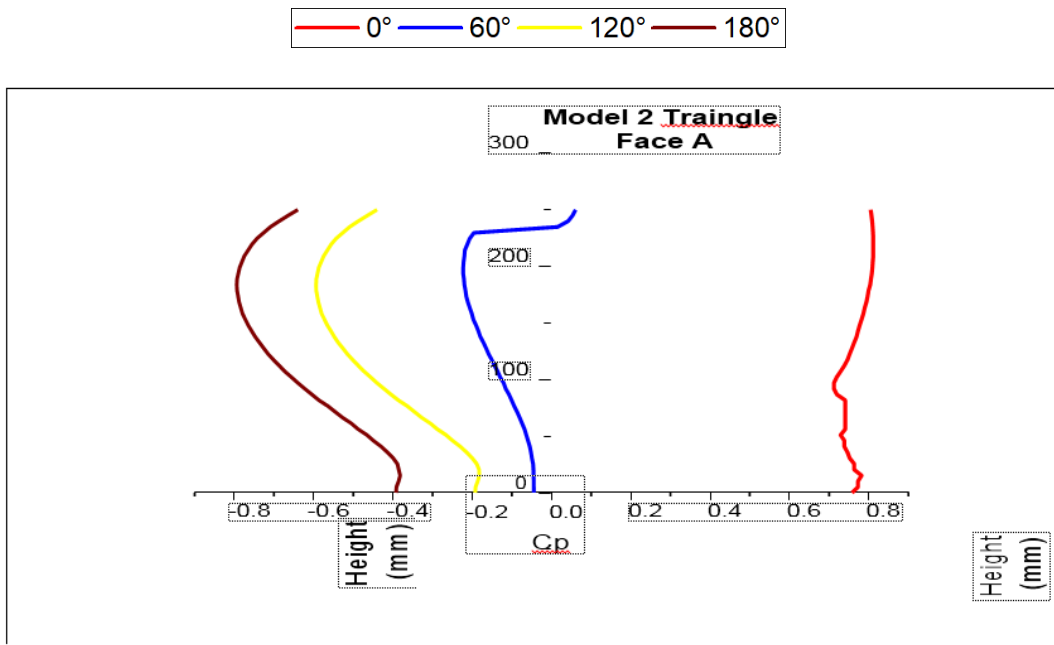

Figure 0-29 Pressure Variation along Centerline for face A for all degrees AOA of model 2

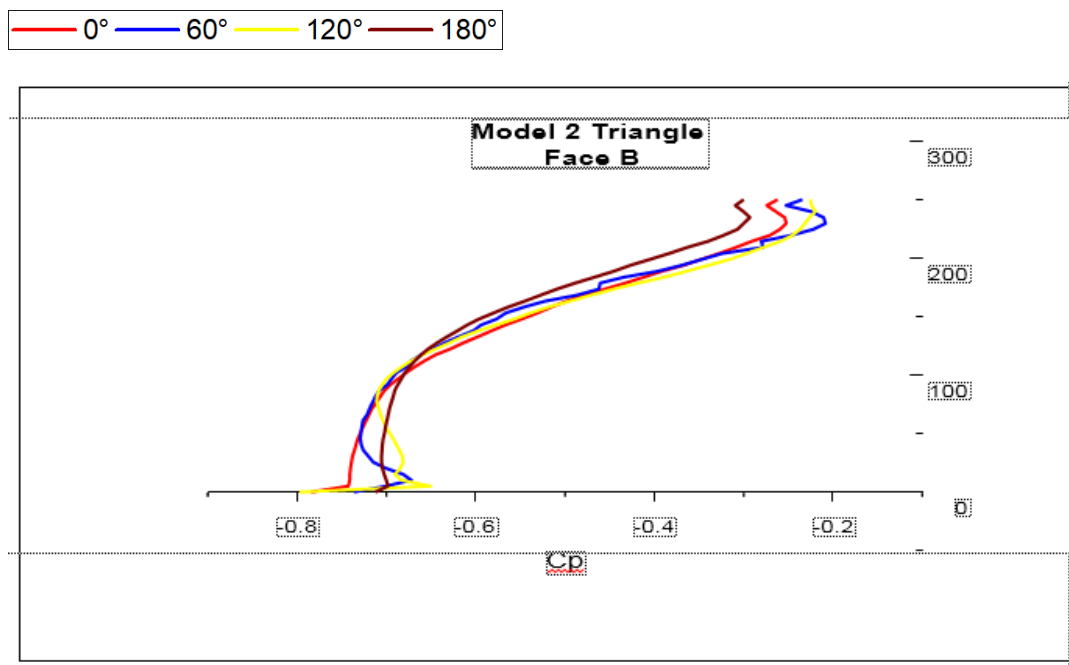

Figure 0-30 Pressure Variation along Centerline for face B for all degrees AOA of model 2

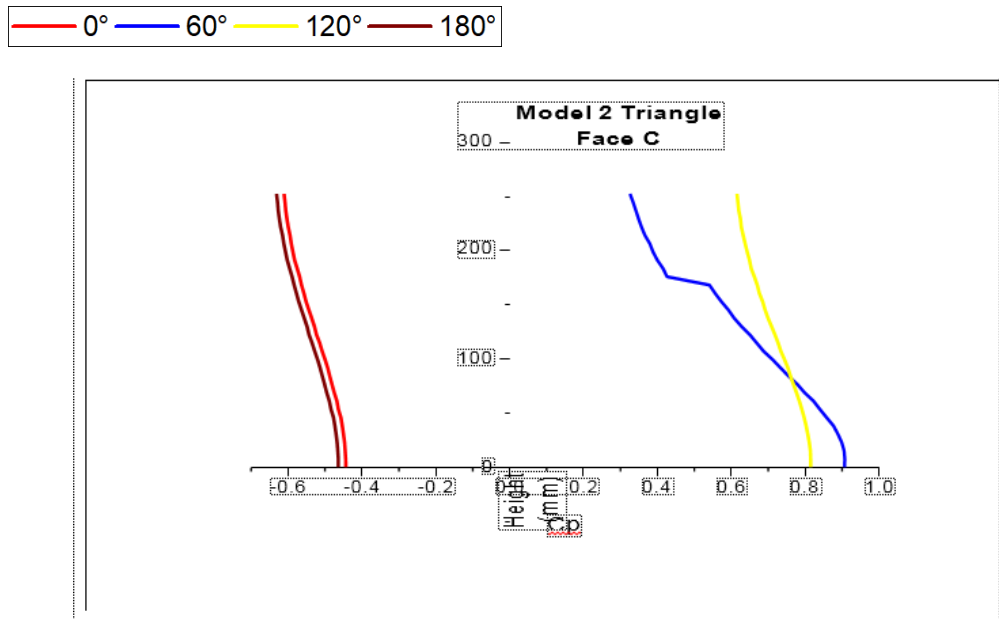
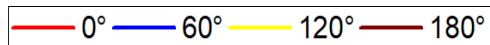

Figure 0-31 Pressure Variation along Centerline for face C for all degrees AOA of model 2

- For faces A of the circular building the mean face average values of C_p at $0^\circ, 60^\circ, 120^\circ$ and 180° angle of attack are +1.2, -2.3, -0.3, and -0.2 respectively.
- For faces B of the circular building the mean face average values of C_p at $0^\circ, 60^\circ, 120^\circ$ and 180° angle of attack are -2.3, -0.2, -2.2, and -2.4 respectively.
- For faces C of the circular building the mean face average values of C_p at $0^\circ, 60^\circ, 120^\circ$ and 180° angle of attack are -.22, -2.25, +1.2, and +.80 respectively.
- For faces D of the circular building the mean face average values of C_p at $0^\circ, 60^\circ, 120^\circ$ and 180° angle of attack are -2.5, +1.0, -2.0, and -2.25 respectively.



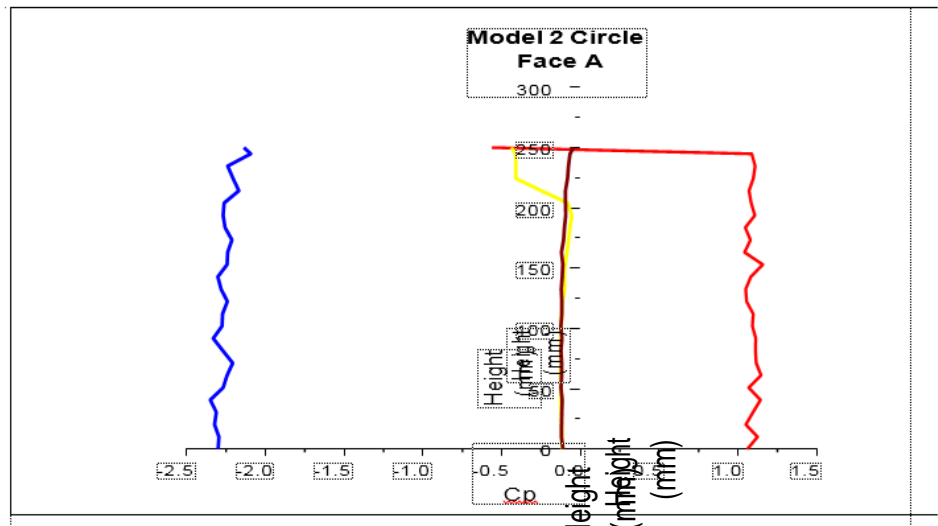

Figure 0-32 Pressure Variation along Centerline for face A for all degrees AOA of model 2

— 0° — 60° — 120° — 180°

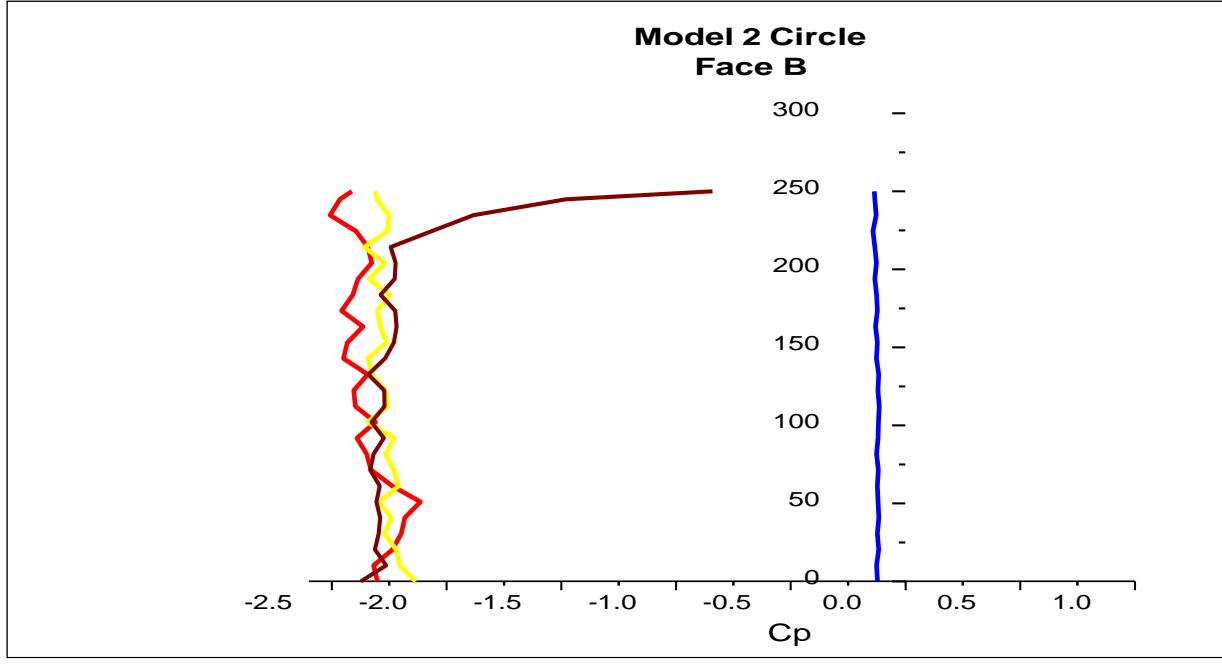

Figure 0-33 Pressure Variation along Centerline for face B for all degrees AOA of model 2

— 0° — 60° — 120° — 180°

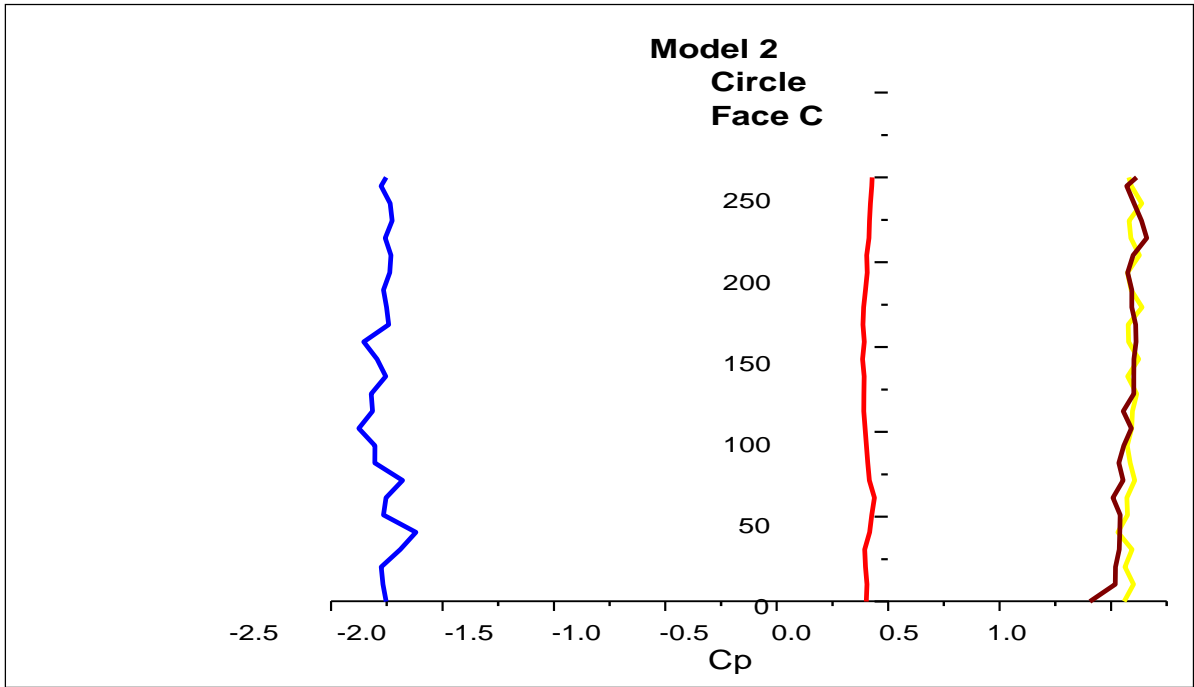

Figure 0-34 Pressure Variation along Centerline for face C for all degrees AOA of model 2

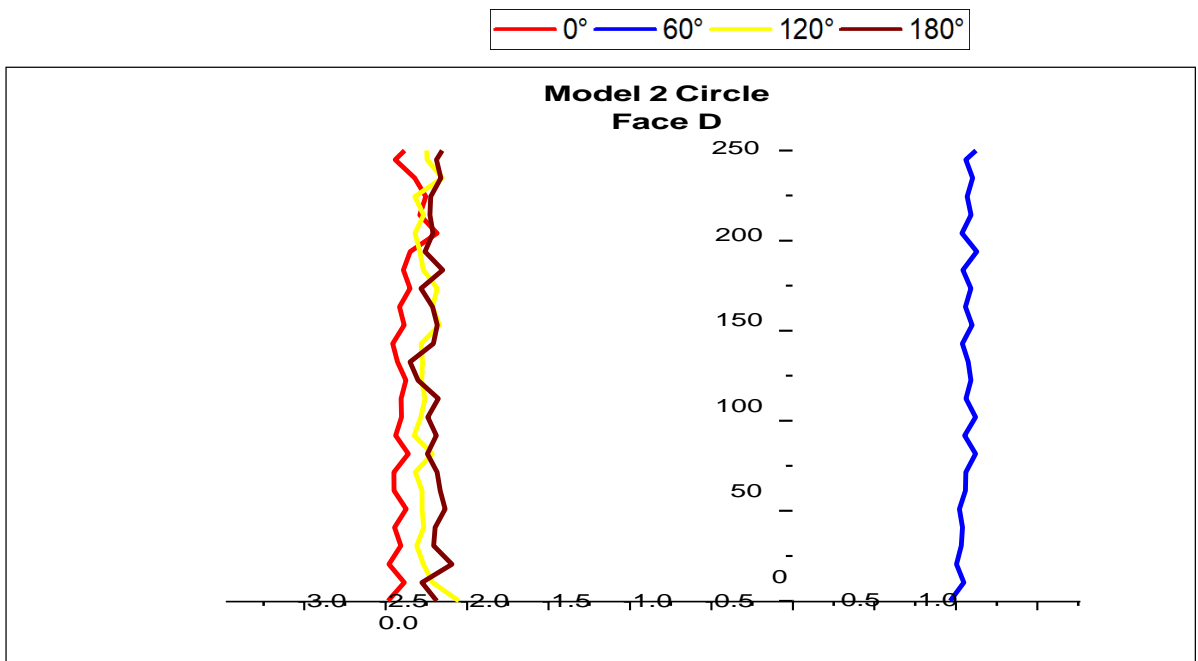

Figure 0-35 Pressure Variation along Centerline for face D for all degrees AOA of model 2

Velocity Distribution

The velocity variation at windward faces of Building are as shown using velocity streamline.

Model- 1 (250 triangle 250 circle)

- Figures 6-1 to 6-4 exhibit the velocity distribution on different faces at different angles of incidence.
- At windward face of the building wind velocity and wind pressure is maximum.
- At 0° and 180° vortex shedding is maximum and can be seen in the fig.
- At 60° and 120° vortex shedding is minimum.
- Wind velocity and pressure is varying at different angle of incidence.
- Red line shows the maximum wind velocity and wind speed whereas blue line shows minimum wind velocity and speed.

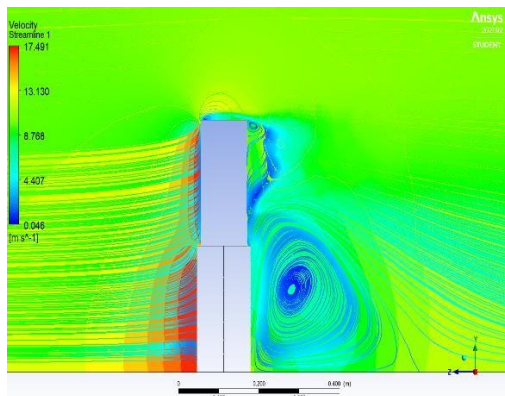

At 0°

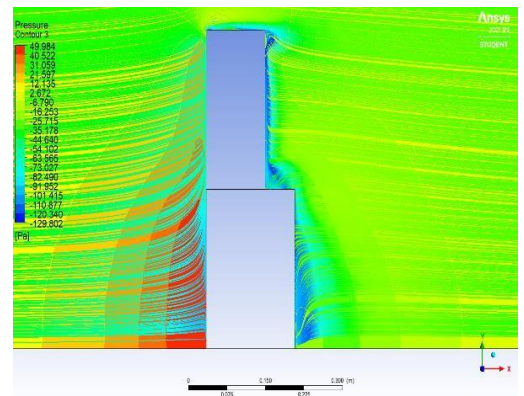

At 60°

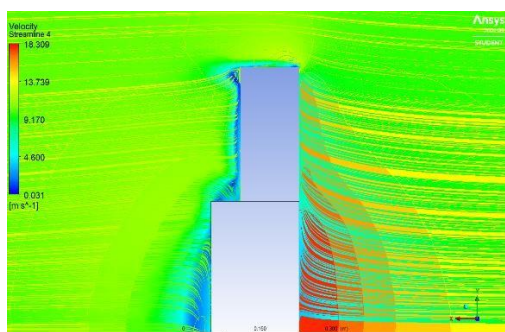

At 120°

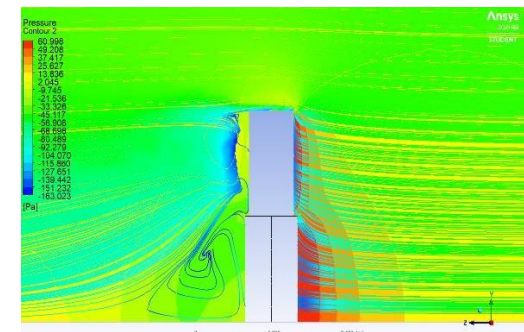

At 180°

Conclusion

The pressure contour and mean pressure coefficients for the triangular and circular-shape building model for different height ratios at 0° , 60° , 120° and 180° wind incidence angles are compared in this paper. The $k-\epsilon$ model is used to simulate the results. The major finding of this research are as follows:

- The influence of height ratios and wind orientations on wind pressure distribution and magnitude of pressure coefficients on triangular and circular building models is identified by numerical study measurement of wind pressures on building models.
- The variation of pressure coefficients on the centreline is discussed and shown graphically.
- Comparison is made for numerical simulation data with various codes.

References

1. Nagar, S., & Ritu Raj. (2020). Experimental study of wind-induced pressures on tall buildings of different shapes. *Wind and Structures, Vol. 31, No. 5 (2020) 441-453.*
2. Ahuja, J. A. (n.d.). Effects of Side Ratio on Wind-Induced Pressure Distribution on Rectangular Buildings.
3. bailey, k. a. (1987-88). Effects of Aerodynamic Modifications of Building Shapes on Wind Induced Response of Tall Buildings.
4. Bairagi, A. M. (n.d.). Wind pressure and velocity pattern around 'N' plan shape tall building.
5. Dalui1, N. A. (n.d.). Aerodynamic analysis of pentagon-shaped tall buildings.
6. Dalui2, B. B. (n.d.). Experimental and Numerical Study of Wind-Pressure Distribution on Irregular-Plan-Shaped Building.
7. Dalui2, P. S. (n.d.). Comparison of aerodynamic coefficients of various types of Y-plan-shaped tall buildings.
8. Franke, J., & Hirsch, C. (n.d.). Recommendations on the use of CFD in wind engineering.
9. Kastner, P., & Dogan, T. (2020). Streamlining meshing methodologies for annual urban CFD simulations. *Journal of Energy and Buildings.*
10. M. Mallick, A. M. (n.d.). Modelling of Wind Pressure Coefficients on C-Shaped Building Models.
11. On the domain size for the steady-state CFD modelling of a tall building . (n.d.).
12. Pal, S., & Ritu Raj. (2021). Comparative study of wind induced mutual interference effects on square and fish-plan shape tall buildings. *Elsivier.*
13. Q.S. Li, J.Y. Fu, & Y.Q. Xiao. (n.d.). Wind tunnel and full-scale study of wind effects on China's tallest building.
14. R. Sheng a, b. L. (n.d.). Wind tunnel study of wind effects on a high-rise building at a scale of 1:300.
15. R. Sheng, L. Perret, & I. Calmet. (n.d.). Wind tunnel study of wind effects on a high-rise building at a scale of 1:300.
16. Suresh K Nagar1a, R. R. (n.d.). Experimental study of wind-induced pressures on tall buildings of different shapes.
17. R. Ahlawat and A. Ahuja, "Wind Loads on T Shape Tall Buildings," *J. Acad. Ind. Res.*, vol. 24, no. 1, p. 257922, 2015.
18. R. Ahlawat and A. K. Ahuja, "Wind loads on Y plan shape tall building," *Int. J. Eng. Appl. Sci.*, vol. 2, no. 4, p. 257946, 2015.
19. IS: 875 (2015), *Indian Standard design loads (other than earthquake) for buildings and structures-code of practice, part 3(wind loads).* 2015.
20. ASCE: 7-10(2013), *Minimum Design Loads for Buildings and Other Structures.* Structural Engineering Institute of the American Society of Civil Engineering,

- Reston*.2013.
21. GB 50009-2001, *NATIONAL STANDARD OF THE PEOPLE'S REPUBLIC OF CHINA*. 2002.
 22. AS/NZS:1170.2(2011), *Structural Design Actions - Part 2: Wind actions. Standards Australia/Standards New Zealand, Sydney*. 2011.
 23. Hong Kong Building Department, "Code of Practice on Wind Effects in Hong Kong 2019," 2019.