

**How to Cite:**

Simran, S., Sinha, P., & Peter, J. S. P. (2022). IOT based vehicle accident detection system. *International Journal of Health Sciences*, 6(S3), 5247–5253.

<https://doi.org/10.53730/ijhs.v6nS3.7080>

## **IOT based vehicle accident detection system**

**Simran**

Undergraduate Student, Computer Science and Engineering, SRM Institute of Science and Technology, Kattankulathur, Tamil Nadu – 603203, India

Email: [sz2736@srmist.edu.in](mailto:sz2736@srmist.edu.in)

**Priya Sinha**

Undergraduate Student, Computer Science and Engineering, SRM Institute of Science and Technology, Kattankulathur, Tamil Nadu – 603203, India

Email: [ps9332@srmist.edu.in](mailto:ps9332@srmist.edu.in)

**J. Selvin Paul Peter**

Assistant Professor, Computer Science and Engineering, SRM Institute of Science and Technology, Kattankulathur, Tamil Nadu – 603203, India

Email: [selvinpj@srmist.edu.in](mailto:selvinpj@srmist.edu.in)

**Abstract**---In the 21st century, it has become impossible to live without motor vehicles. With the increasing demand of vehicles, a rise in accidents is seen as well. According to the World Health Organization, nearly 1.3 million deaths are caused by road accidents. Most of the time, a person involved in an accident is left unattended or the help is delayed. Our project helps the person by alerting the family using GPS, GSM and Wi-Fi. So that the person can be helped as soon as possible.

**Keywords**---GPS, GSM, Wi-Fi, IoT, microcontroller.

**Introduction**

With the increase in the number of automobiles. The accidents have also increased leading to life risks. In a developing country like India, emergency medical support is not very advanced. This results in the loss of precious lives. Most of the people involved in accidents die due to a lack of immediate help. Our project is a real-time solution to this situation. The system installed in the car will use GPS, GSM, Wi-Fi and sensors and then inform the person's family about the accident along with the person's location. Thus, providing help on time. Our project helps in detecting the exact location of the accident. The system is to be installed in the car. When the vehicle runs normally i.e., there is no abnormality and the accident has not yet occurred then no alert message/email is sent. when the vehicle encounters an accident, the orientation of the vehicle is changed. The

change in orientation produces a spectrum of waves and the frequency also increases. The MEMS sensor detects the abnormality in the vehicle. The controller Then receives input from a no. of sensors and sends an alert message and email to the pre-saved family contacts and the email address. This message and email contain the exact location of the site of the accident through the GPS, GSM and Wi-Fi module. It also facilitates connectivity with the family members and provides immediate assistance through IoT.

### **Related works**

In the current scenario, we cannot identify the scene of the accident and the information about the person's death. An intense investigation is underway to track vehicles in dark and confusing areas with poor network reception. A variety of approaches to ensuring safety through real-time vehicle monitoring and precise positioning and awareness are explored in the literature using a variety of technologies. An exceptional study of vehicle tracking using GPS has been done by [Ni Ni San Hlaing, Ma Naing, San San Nainget et al, 2013]. A GPS-based vehicle tracking system shows the real time location of the car and the GSM module helps in sending messages containing the location of the accident site. Users can continuously monitor the real-time location of the vehicle on demand. This also helps to give an estimation of time to reach a certain destination.

In the paper presented by S.Madhuri, K.Bhuvana Jyothi, Ch.Indraja, Swarna Bai Arniker, K.Sita Rama Raopaper. We studied GPS technology, Arduino embedded system, Arduino IDE open source based hardware and the test results of a Passive Vehicle Tracking system.

### **Methodology**

In our proposed system we have combined hardware and software components as described below:

#### **Microcontroller**

It receives information from the MEMS sensor and then further processes it. The microcontroller board used is Arduino Nano which is based on the Atmega328p microcontroller. The chipset used is AVR (8 bit) and RAM type is SRAM.



Figure 1. Arduino Nano

#### **GPS Module**

We have used Neo-6MV2 GPS. It contains tiny processors and antennas that receive data from the satellite. It has its own storage and processing capability, so it takes less load time when it is running while integrating with the sensor. It

detects the location and then the information is taken by the microcontroller which is further used by the GSM module to send messages to the medical facility and relatives.



Figure 2. Neo-6MV2 GPS

### GSM Module

In our proposed system, we have used SIM900a GSM. It helps in establishing communication between a computing machine and a GPS system. It can work in various ranges of frequency. It typically ranges between 900MHz to 2-8GHz.



Figure 3. SIM900a GSM

### WI-FI Module

We have used ESP8266 as the Wi-Fi module. The ESP8266 WiFi Module is a self-contained SOC with an inbuilt TCP/IP protocol stack that can provide access to WiFi networks for any microcontroller. Each ESP8266 module comes preprogrammed with AT command set firmware, so you can just plug it into your Arduino and get about as much WiFi functionality as a WiFi Shield. The ESP8266 module is a low cost board with a large, and rapidly increasing, community. When an accident is detected, an alert email is sent to the pre-saved email address of the victim.

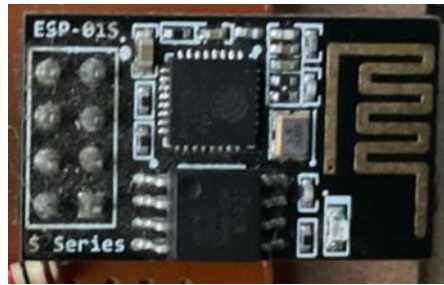

Figure 4. ESP8266 Wi-Fi Module

### LCD Display

The LCD displays the message system started on switching on the system. Then, a message is displayed when the ADXL sensor calibrates. It will display the coordinates detected using the GPS module.



Figure 5. 16X2 LCD

### ADXL Sensor

An accelerometer sensor is an instrument that measures the acceleration of any object or objects within its instantaneous resting frame. We have used an ADXL sensor to sense the change in acceleration.

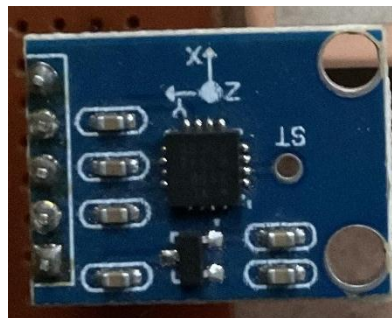

Figure 6. ADXL335

We have used the Arduino IDE to write and run our codes. The Arduino IDE is an open-source electronic platform that helps in sending instructions to the microcontroller board. We have used several libraries such as software serial library, liquid crystal library, ESP8266 WiFi library, ESP-Mail-Client library, etc.

With the help of gps the system tracks the location coordinates of the accidental site. A message and mail is sent to the pre-saved contacts using gsm and esp respectively. This way the concerned person is informed of the accident.

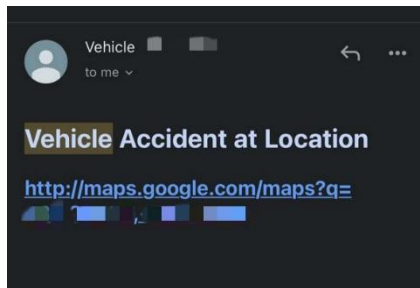

Figure 6. Alert Message sent to the pre-saved contact number

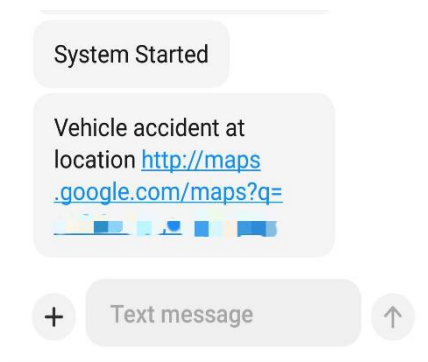

Figure 7. Alert email sent to pre-saved email id

### System design architecture

When the system is switched on a message is displayed on the LCD which shows 'System Started'. The same message is sent to the pre-saved contact number as well. The ADXL sensor is calibrated. As the vehicle moves, the microcontroller continuously gets the values from the sensors. When the values show any abnormality i.e., an accident has occurred, the microcontroller processes it and activates the GPS module. The GPS module then finds the exact location of the accident. The GSM and Wi-Fi Module help in sending an alert message to the pre-saved contacts through text message and email. This alert message contains the location of the accident in the form of a Google Map link. This message helps the family members of the victim to reach the accident site and provide immediate medical assistance. In case there is no abnormality in the values from the sensor i.e., accident has not occurred, then no alert message is sent. The system is switched off when the vehicle is switched off.

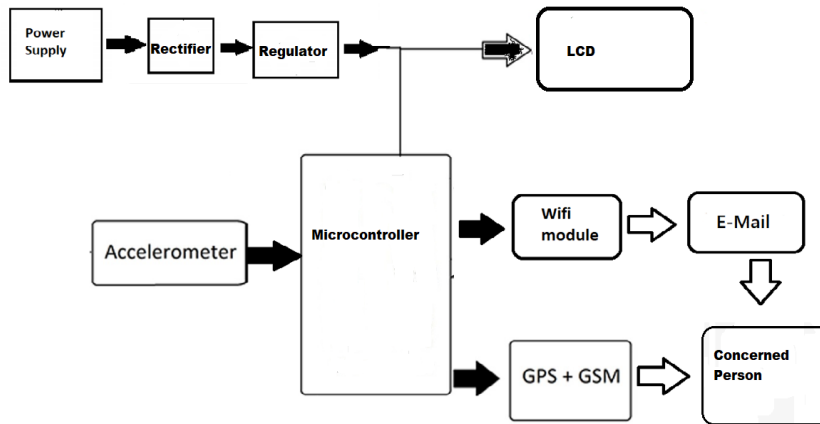

Figure 8. System Architecture

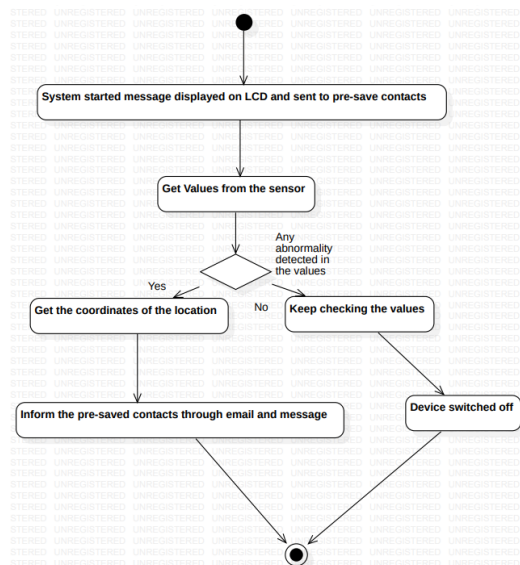

Figure 9. Work-flow of the proposed system

## Results and Discussion

When the vehicle runs normally i.e, no accident has occurred yet the no alert message is sent. When the vehicle encounters an accident, it changes its orientation. The change in the orientation of the vehicle produces a spectrum of waves and the frequency also increases. The MEMS sensor spots the irregularity within the vehicle. The controller is then activated by the inputs from the sensors. This in turn activates the GPS-GSM module and sends an alert message to the pre saved contacts of the victim. It also sends alert emails to the pre-saved email address. Thus, the victim receives immediate medical assistance through IOT.



Figure 10. IOT based Vehicle Accident Detection System

### Conclusion

The system that we have presented works as an alert system to detect and report accidents by using GPS, GSM technologies. The sensor detects the accident and then the microcontroller takes the charge using GPS to detect location and then use GSM to report the accident to the family of the person by sending a message stating that the person is involved in an accident. It also sends an alert email to the pre-saved email address that contains the location of the accident site. This will be really helpful for the injured, who are in no position to contact someone. There is always room for improvement, we hope that this project integrated with the technologies that will be introduced in the future can become the device of the future.

### References

- D. Bajaj and N. Gupta, "GPS Based Automatic Vehicle Tracking using RFID", *International Journal of Engineering and Innovative Technology*, pp 31-35, Jan 2012.
- B.Kodavati, V.K.Raju, S.S.Rao, A.V.Prabhu, T.Appa Rao, Y.V.Narayana, "GSM and GPS based Vehicle Location and Tracking System", *International Journal of Engineering Research and Application*, pp. 616-625
- Ms.MehaSoman, Shruthi R, Sangeetha J, Ramya R, Ramyalakshmi T, "IOT Based Automatic Vehicle Accident Tracking Down And Salvage System Using GSM", *International Research Journal of Engineering and Technology (IRJET)*, Volume: 05 Issue: 03, Mar-2018.
- S.Kotte, H.M. Yanamadala, "Advanced Vehicle Tracking System on Google Earth using GPS and GSM", *International Journal of Computer Trends and Technology*, pp. 130-133, 2013.
- Swetha Bergonda, Shruti, Sushmita, Savita Soma, "IoT Based Vehicle Accident Detection and Tracking System Using GPS Modem", *International Journal of Innovative Science and Research Technology*, Volume 2, Issue 4, April- 2017.
- S.Madhuri, K.Bhuvana Jyothi, Ch.Indraja, Swarna Bai Arniker, K.Sita Rama Rao, "GPS based Passive Vehicle Tracking Using Arduino", [https://www.researchgate.net/publication/321212118 GPS based Passive Vehicle Tracking Using Arduino](https://www.researchgate.net/publication/321212118_GPS_based_Passive_Vehicle_Tracking_Using_Arduino), November 2014.