

**How to Cite:**

Procomet, P., & Setthachotsombut, N. (2022). Enhancing cross-border transportation capabilities of road freight entrepreneur Chong Chom permanent border crossing, Thailand-Cambodia. *International Journal of Health Sciences*, 6(S5), 397–417.  
<https://doi.org/10.53730/ijhs.v6nS5.7838>

## **Enhancing cross-border transportation capabilities of road freight entrepreneur Chong Chom permanent border crossing, Thailand-Cambodia**

**Pannarai Procomet**

Suan Sunandha Rajabhat University, Thailand  
Email: [s61484923010@ssru.ac.th](mailto:s61484923010@ssru.ac.th)

**Natpatsaya Setthachotsombut**

Suan Sunandha Rajabhat University, Thailand  
\*Corresponding author email: [natpatsaya.se@ssru.ac.th](mailto:natpatsaya.se@ssru.ac.th)

**Abstract**--The objectives of this research are to study ways of Enhancing Cross-Border Transportation Capabilities (ECTC) of road freight forwarders: Chong Chom permanent border crossing point, Thailand-Cambodia, to build ECTC model, and to study the effect of ECTC on Transport Entrepreneur Capabilities Performance (ECP) by using mixed methods research design. Population was 12,546 entrepreneurs and employees of 20 road freight forwarders in Bangkok, Surin and Nakhon Ratchasima. The total of 780 questionnaires was distributed and then 527 were returned. Moreover, in-depth interview was from 18 key informants. The research instrument was tested in terms of reliability and validity. Data was analyzed using a variety of statistics including descriptive statistics, Confirmatory Factor Analysis (CFA), Structural Equation Model (SEM) and Path Analysis. The results have found that Cooperation and Participation (CP) is most important factors for ECTC. In addition, the structure of ECTC model consists of 4 constructs: Enhancing Cross-Border Transportation Capabilities (ECTC) ( $\alpha = 0.83 - 0.92$ ), Transport Operation (TROP) ( $\alpha = 0.81 - 0.87$ ), Cooperation and Participation (CP) ( $\alpha = 0.85 - 0.89$ ) and Entrepreneur Capabilities Performance (ECP) ( $\alpha = 0.74 - 0.85$ ). Moreover, ECTC has no direct effect on ECP (DE=0.11) but sub-factors of ECTC, including TROP and CP, have a total effect on ECP at a highest level (TE= 0.95 and TE= 0.99, respectively). In conclusion, although ECTC has no direct effect on ECP, the adoption of this model for cross-border transportation will help entrepreneurs improve their capabilities in all aspects such as the reductions in waiting time, error, costs, risks in

working processes and operational interruptions as well as the development of customer's value.

**Keywords**---enhancing capabilities, cross-border transportation, freight entrepreneur, Thailand-Cambodia.

## Introduction

Thailand is the center of Southeast Asia bordering with Myanmar Lao People's Democratic Republic, Cambodia and Malaysia make border trade important. Thailand's provinces bordering with neighboring countries consists of 4 northern provinces, namely Ubon Ratchathani, Sisaket, Surin and Buriram, 3 western provinces, namely Sa Kaeo, Chanthaburi and Trat. There is also a border trade point between Thailand and Cambodia, which is a permanent border crossing point and a relief point in 4 northeastern provinces, namely Surin, Ubon Ratchathani, Sisaket and Buriram (Trade and Investment Information Center with Neighboring Countries, 2020). At present, the situation in border trade of Surin Province - Udonmeechai Province generally notifies that Surin Province borders the Kingdom of Cambodia with 4 districts, namely Buachet, Sangkha, Kap Choeng and Phanom Dong Rak. It has a length of approximately 90 kilometers along the border with the permanent border crossing point at Chong Chom, Kap Choeng District, Surin Province, which has been elevated from the trade relief point to the permanent border crossing point of Chong Chom - Or Samet on September 1, 2002, opening daily from 6:00 a.m. - 10:00 p.m. The value of the Thai-Cambodian border trade Chong Chom - Or Samet has export value of 1,049.11 million Baht in October 2020. The top 10 export products are 1) piglets, pigs, 2) green tea drinks, soft drinks, energy drinks ,3) UHT milk drinks, milk soybeans, 4) frozen food, canned food, 5) processed sausage meatballs, 6) non-dairy creamer, milk for cooking, 7) red instant tea powder, 8) instant cup noodles with Tom Yum Kung Sauce, 9) GREEN MATE mixed fruit juice, and 10) 3/4 liter Oleen palm oil (Chong Chom customs checkpoint Surin Province, 2020).

The study of the problems in cross border transport of road freight operators at Chong Chom permanent border crossing point, Thailand - Cambodia, through interviews and surveys, found that: 1) In cross-border cargo operations, there was an error in preparing the shipping documents such as invoices for moving goods, export declaration and tax invoice, by which the process must go through the Chong Chom customs checkpoint to submit the documents causing the cross-border transportation to be interrupted, delayed and causing no trust from customers, 2) transportation was not prepared since there was a truck breakdown during the cross-border delivery route to customers from Thailand - Cambodia, causing waste of time in transporting goods across the Thai-Cambodian border, by which the vehicles and drivers must be carefully inspected, 3) in the situation of the epidemic of corona virus or COVID-19 (Aunyawong et al., 2021), the government has a policy that when the drivers who deliver goods across the border arrived the permanent border crossing point at Chong Chom,

they will be replaced with domicile drivers in Ban Dan Subdistrict, Kap Choeng District, Surin Province, resulting in higher costs, delivery delays and Cambodia customers' expenses, and 4) the government agency, Chong Chom Customs, and cross-border freight forwarders have few joint meetings, with only one meeting in a year, causing insufficient coordination and errors in customs clearance.

However, due to the aforementioned problems, it is necessary to improve the efficiency of freight forwarding of Thai freight forwarders to be more efficient in order to survive in the transportation business and build their competitiveness (Soonthornpipit et al., 2021). As a result, the research aims to The objectives of this research are to study ways of Enhancing Cross-Border Transportation Capabilities (ECTC) of road freight forwarders: Chong Chom permanent border crossing point, Thailand-Cambodia, to build ECTC model, and to study the effect of ECTC on Transport Entrepreneur Capabilities Performance (ECP)

### **Hypothesis**

- H1: Enhancing Cross-Border Transportation Capabilities (ECTC) has a positive direct effect on Entrepreneur Capabilities Performance (ECP)
- H2: Transport Operation (TO) has a positive direct effect on Enhancing Cross-Border Transportation Capabilities (ECTC)
- H3: Cooperation and Participation (CP) has a positive direct effect on Enhancing Cross-Border Transportation Capabilities (ECTC)
- H4: Enhancing Cross-Border Transportation Capabilities (ECTC) mediates the positive effect of Transport Operation (TO) on Entrepreneur Capabilities Performance (ECP)
- H5: Enhancing Cross-Border Transportation Capabilities (ECTC) mediates the positive effect of Cooperation and Participation (CP) on Entrepreneur Capabilities Performance (ECP)

### **Literature review**

#### **Capability Enhancement**

Capability is the ability to perform tasks. It will set acceptable performance measurement standards. Capabilities can be grouped in many characteristics, such as core capability, which is necessary for all employees in the organization, and Functional capability, which is the ability that employees who work in specific position in each department with job skills. The performance maximization may be measured using the maximum amount of production or service resources compared to the productivity or work. It also can be measured by costs and profitability (Aunyawong et al., 2020). If waste occurs vastly, it reflects poor performance or low operational efficiency (Nimit Siriwan, 2011; Pintuma et al., 2021). Increasing performance requires the up-to-date and sufficient tools for supporting work (Wattananarangsana & Suthanyarak, 2016). Capability enhancement is what helps the organization to anticipate, manage,

control and continue to operate the business under a high competitive environment (Setthachotsombut & Aunyawong, 2020), so it is the increase the employees' capability to meet the specified standards or criteria as well as to work above the specified threshold. Moreover, the capability of equipment, machinery, vehicles or the availability of assets is to increase the existing capacity for the benefits of the organization.

### **Cross-Border Transportation**

Transportation means the management regarding the movement of people or things by vehicles or tools from one place to another (Setthachotsombut, 2020). The modes of transport are divided into road, rail, sea and air. Transportation costs, environmental emissions and social risks are determined differently (SteadieSeifi et al., 2014). Transportation in Thailand relies mostly on road transport by trucks both domestic and cross-border transport which is very important to the country's economic system (Nualkaw et al., 2021). Transportation systems are complex (Muerza et al., 2017), especially in cross-border transport of goods by road. The efficiency level of the freight is measured by service time to meet customer needs (Fulzele et al, 2019). Cross-border freight is transport through Thailand from a customs house that transports goods into to another customs house where the goods are transported under customs control with the beginning and end of the transport outside the Kingdom. The conveyance of item may be changed in terms of vehicles, storages and containers for the benefits of transportation. The mode of transport can be changed without any behaviors for commercial gain in connection with the goods during transit through Thailand (Department of Customs, 2021).

### **Thai-Cambodian Chong Chom permanent border crossing point**

The Thai-Cambodian Chong Chom permanent border crossing point was established for the year 2010, connecting road transport between Surin Province of Thailand and Udon Meechai Province of Cambodia, Route 214 (Surin-Chong Chom), a distance of approximately 70 kilometers. Goods, such as Oishi beverages, Dairy cattle from Saraburi Province of Thailand, plastic bags, Thai tea, Ichitan drinks, canned fruit juice will be transported to neighboring countries by using trucks to deliver the products to the distribution center located at Or Samet District, Udon Meechai Province, Cambodia. Most of the products originated from Nakhon Ratchasima and Bangkok of Thailand. In addition, the inbound goods from Cambodia imported to Thailand are mangos, cassava, packed in stacked boxes, palletized and containers, and cement, packed in bags. The choice of packaging and the mode of transportation will depend on the types of cargo to be carried in each round. The outbound transportation takes only one day. Most of the vehicles used for transportation are 18-wheel trailer trucks. The border crossing period will be open from 6:00 a.m. to 10:00 p.m., but the goods will arrive in front of the customs house through the outbound border at around 8:30 p.m. While the period of time that the goods crossing the inbound border will return to

the checkpoint no later than 3.00 p.m. Trucks that transport goods across the border will be parked in front of the Chong Chom customs checkpoint to submit documents such as invoices for moving goods, export declaration, tax invoice, with Chong Chom customs officer inspecting 2 categories of goods: 1) risk category (companies that have never brought goods across the border), and 2) the category of the companies that have a history of transporting goods across the border.

### **Enhancing Cross-Border Transportation Capabilities**

Enhancing cross-border transportation capabilities is to increase the capacity of road freight operators in the management of cross-border freight transport, passing through the Chong Chom permanent border crossing point Thailand-Cambodia to upgrade the transport capability from the original to a higher level of capability and to be beneficial to the operations of the organization by increasing the capacity of cross-border freight transport from the development of capability in 3 main areas, namely, cross border operation, government regulations and agility.

- **Cross border operation** is the preparation of documents for transportation of goods through the border. It is necessary to list information clearly and accurately according to customs regulations, leading to cross-border transport controls such as documents and e-commerce policies in cross-border shipping. The policy must specify goals, oversight, and policy measures. This will involve tax collection and warehousing (Weihua et al., 2019), as well as customs clearance of cross-border road transport. Bilateral agreements, besides, will lead to controlling cross-border transport (Monyepao, 2015), checking the nature of the transport document (Schmiz, 2011), preparing of export documents to meet the document conditions. Documents are extremely necessary to show clearly (Hang Yen Low, 2010).
- **Government regulations** refer to an action related to the operation of the law (Department of Land Transport, 2019), such as entering Authorized Economic Operator (AEO) system according to the government's policy. An organization or company that is responsible for the movement of goods need to be certified by the customs of each country that it complies with the WCO framework or equivalent standards for supply chain security. The firms need to operate in accordance with the law, conditions, rules and regulations of customs procedures strictly (Kedkanok Chuamawan et al., 2018) by training and educating employees in order to know the rules for transporting goods across borders both Thailand and Cambodia. There is a study of information on the rules for transporting goods across borders to be a guideline for transportation management in order to have standards in cross-border transport of goods, let employees operate in accordance with the correct rules, and deliver products across borders to customers within the specified time and customs expertise (Chofer, 2017), such as submitting documents related to cross-border shipments to customs officials in a

complete and accurate manner as well as liaising with customs officials in advance of cross-border shipments.

- **Agility** is the speed of problem solving (Ismail, 2019), for example, employees should make quick decisions to solve problems arising in border freight and promptly report to the company that there is a problem in order to prevent the organization from having an impact and damage (Srisawat & Aunyawong, 2021). The firms, therefore, should support employee empowerment (Wisedsin et al., 2021) Agility in assessing the situation and implementing appropriate solutions (Hinkka, 2015) is cross-border freight operations and agile employee judgment that enhances the organization's capacity to be more efficient and accepted by customers. Employee agility and clarity of work procedures are that employees should self-assess their past performance annually in order to use the information gathered to improve and develop their potential (Prabhakaran & Sudhakar, 2015).

### **Transport Operation**

Quality standards for trucking services have a fundamental concept for improving the quality of trucking services in order for users to be impressed and confident in using the services and at the same time to ensure the safety of the transportation business. Therefore, transport operators must adapt to the changes in costs and services and develop themselves to have the ability to compete with foreigners. The quality standards of trucking services have various requirements covering five aspects of the trucking operations process, namely organization, transportation operations, employee, vehicle, and customer and external aspects (Department of Land Transport, 2019). The transport operation process is a method and procedure for transporting goods by road across borders. The process of transport operations must have vehicle preparation, cross-border carriage documentation, transportation risk management, transportation staff skills development and transportation tracking and report.

- **Vehicle preparation** will be able to increase productivity per hour and reduce both travel distances, especially autonomous driving vehicles (Jinxin et al., 2020). Vehicles must be equipped with reliable communication and technology. They also need to be prepared for transportation in emergency situations, survey of road conditions for road safety, planning to shorten time and distances (Hanson et al., 2015), and multimodal transport schedules (Liu, 2015). To transport goods across borders, information system technology should be used to manage the preparation of vehicles to get information fast (Department of Land Transport, 2019). Employees should be knowledgeable, study road conditions in Thailand - Cambodia cross border cargo and prepare transport equipment (Suthasinee Roopkaew and Phonsan Phosrithong, 2019), for example, planning on appropriate control strategy to respond to changing traffic patterns and demands, a computer model for transportation data processing for vehicle troubleshooting, as well as facilities. Training on transport operations in

both theoretical and practical sections for employees to be effective pre-check and forecastable for facilitating cross-border freight before cross-border shipments (Jesús García-Arca et al., 2018).

- **Transportation Risk Management** prevents risks that may arise in cross-border freight forwarding. It is a decision to deal with shipping risks that will affect the company's goals (Schoenherr et al., 2008). The sources of risks come from supply risk, process risk, demand risk, control risk and environmental risk (Christopher & Peck, 2004). The causes of the risks are supply chain uncertainty (Melnyk, 2007), vulnerability (Wagner & Neshat, 2010) and complexity (Boyle et al., 2008). Poor risk management affect the company's performance (Schoenherr et al., 2008). Therefore, a good management model is required for the transportation process, event supervision, risk management when work is interrupted to integrate talent with stakeholders (Giannakis & Louis, 2011).
- **Transportation staff skills development** is an organizational human resources plan. The transport operations depend on the participation of all employees who work for the benefit and achievement of the Company's goals (Ismail, 2019). The firm will promote skills and expertise in a variety of operations, creative problem solving, and training program for old and new employees, as well as clearly define obligations, personal responsibility, employee morale maintenance, employee engagement and business ethics to have a high capacity to work for the competition and strive for the organization (Setthachotsombut, 2020). Transport team must work as a team, has facilities, pay attention to the responsibilities of team members, and has a strong team culture (Ponomariov & Kingsley, 2012; Rahman, 2012), so the development of freight forwarder skills can have a positive effect on enhancing capabilities of cross-border freight and freight forwarders.
- **Transportation tracking and report** is an operation in the field of checking the facts of transportation operations and reporting a problem Results in performance during the day or at intervals by using efficient cargo tracking technology and application to improve logistics operations and control (Chofer, 2017). Transportation tracking and report depend on technological quality control to improve transportation operations (Meyer, 2013), using the RFID system (Hinkka, 2015), on time and correct delivery, accurate data presentation (Perego et al., 2011) and data analysis (Kuehnhausen & Frost, 2011).

### **Cooperation and participation**

Cooperation is the ability to work effectively with other entities for mutual benefit (MacCormack & Forbath, 2008). Organizations need to look for opportunities from outsiders to collaborate and coordinate with partners (Lin et al. al., 2010) to establish cooperation between customs government agency resulting in effective integration of inter-organizational cooperation (Chang et al., 2020), including the creation of inter-organizational cooperation for border management. Cooperation

between organizations will increase the skills and share collaborative resources effectively. This is good for border cities (Yeo, 2020). Cooperation and participation of cross-border freight forwarders with both internal and external stakeholders emphasize collaboration in work together effectively, such as promoting cooperation with organizations, partners, customers and relevant government agencies. Information is shared and clearly creates conditions for working together where cooperation and participation must be established for customs clearance as well as coordination, communication and participation of the relevant parties. Cooperation and participation includes the creation of cooperation for customs clearance, coordination, communication and participation of the involved stakeholders.

- Building Customs Cooperation is building cooperation to carry out customs formalities to bring goods across borders. The company emphasizes cooperation in working effectively with internal and external departments (Esper et al., 2007), such as promoting cooperation with partners or government agencies (Tariq Al-Shbail & Aini Aman, 2017) by sharing information to operate and comply with the conditions and regulations of cross-border shipments. Clear cooperation can help to avoid delays caused by long waiting time and incomplete official papers in documentation process. At present, conducting customs formalities to bring goods across borders has brought information technology and modern equipment for use in management services, including the application of online information systems in customs (Setthachotsombut, 2020). When cooperation is established for good customs clearance, entrepreneurs will ensure the safety of imported and exported goods as well as be able to expedite cross-border shipments efficiently (Kim Chang-Bong et al., 2016).
- Coordination is the ability to coordinate freight forwarders with other people involved, whether within or outside the organization, government agencies or customers (Lin et al., 2010), to create cooperation in working together for the delivery of goods to the destination at the specified time. The ability of coordination and cooperation, which is the cornerstone of success (Gligor and Holcomb, 2012), make operations quick and flexible in the process of moving goods (Setthachotsombut, 2020). Good coordination system will drive the company's operations to make production and delivery decisions that can lead to excellent company performance (Jenei et al., 2006) and organizational efficiency advancement (Nawata, 2020).
- Communication is that the company has an efficient internal and external communication system, contributing to the channel of building relationships and providing information accurately and quickly (Setthachotsombut, 2020). Communication is to share existing information and to plan further improvements of information. Many important public and private decisions are based on the accuracy and strength of communication data (Tardiff & Ontario, 2017). Communication across different cultures is also important. This must be done effectively to foster mutual understanding (Amer and Johannes, 2015), for example, the communication between Thai and Cambodian truck drivers, where the company needs to change drivers when transport goods across borders and has reliable communication to maintain the connection between the vehicle



and the driver (Dey et al., 2016). Exchanging and sharing information with each other have an efficient internal and external communication system, increasing the efficiency of cross-border transportation.

- Involvement of stakeholders is an involvement of people involved in cross-border freight forwarding by giving opportunity for those involved in the work to express their opinions and share information. To create participation in the transportation management process, stakeholders must have opportunity in decision-making (Burkovkis Raimondas, 2010) as well as strategic cooperation in the development of cross-border freight forwarding and effective stakeholder engagement mechanisms (Nadiya & Olha, 2012). This can help firms reduce costs, damages and potential risks associated with shipping, facilitate work effortlessly, and ensure that the strategy can be achieved (Burkovkis Raimondas, 2010; Nadiya & Olha, 2012).

### **Research Methodology**

The study used mixed methods research design, combining quantitative and qualitative research methods. These methods were concurrently conducted. Data was collected from medium and large cross-border road freight companies in 3 provinces: Surin, Nakhon Ratchasima and Bangkok.

- **Population and sample**  
Population was 12,546 entrepreneurs and employees of 20 road freight forwarders in Bangkok, Surin and Nakhon Ratchasima (Chong Chom Customs checkpoint Surin Province, 2020). The sample size was determined based on 20 times greater than the numbers of research variables (39 variables x 20 times). Therefore, the total of 780 questionnaires arisen from stratified random sampling were distributed (National Statistical Office, 2012) for the sample to have an equal chance of being selected. Moreover, in-depth interview was from 18 key informants (3 medium-sized companies, 3 large companies, 2 each), determined by purposive sampling. The selection is qualified as an entrepreneurs and staff with knowledge related to research topics and more-than-2-year work experience.
- **Research instruments**  
The questionnaire was verified by 5 experts: 3 academic experts and 2 transportation experts. Content validity was checked for Index of Item Objective Congruence (IOC) (0.87), and reliability was checked for Cronbach's Alpha (0.96).
- **Data collection**  
The quantitative method used the print out questionnaires to collect the data by distributing them at the Chong Chom customs checkpoint and sending them to companies through agents and parcel delivery. However, because sample was facing the problem of COVID-19, in which some employees were infected and quarantined or work from home, from 780 questionnaires distributed, 527 questionnaires were returned, or 67.56%.

While the qualitative method used in-depth interviews via telephone, LINE Call, and Google Meet.

- **Data analysis**

Quantitative data analysis used descriptive statistics, Confirmatory Factor Analysis (CFA), Structural Equation Model (SEM), and Path Analysis. The qualitative data analysis used content analysis to consider the completeness according to the constructs in the research conceptual framework.

## Results

The results were shown in Tables 1-3 and Figure 1, as follows.

Table 1  
Analysis results of constructs using mean and standard deviation

Variable	ระดับการประเมิน		
	$\bar{X}$	S.D.	Level
Enhancing Cross-Border Transportation Capabilities (ECTC)	4.33	0.33	High
Cross Border Operation (CBO)	4.33	0.37	High
Government Regulations (GR)	4.34	0.35	High
Agility (AGT)	4.33	0.35	High
Transport Operation (TROP)	4.29	0.33	High
Vehicle Preparation (VP)	4.28	0.36	High
Transportation Risk Management (TRM)	4.28	0.36	High
Transpiration Staff Skills Development (TSD)	4.26	0.38	High
Transportation Tracking and Report (TTR)	4.34	0.37	High
Cooperation and participation (CP)	4.35	0.33	High
Building Customs Cooperation (BCC)	4.33	0.37	High
Coordination (CDT)	4.35	0.37	High
Communication (CMC)	4.34	0.35	High
Involvement of Stakeholders (ISH)	4.38	0.36	High
Entrepreneur Capabilities Performance (ECP)	4.32	0.34	High
Waiting Time Reduction (WTR)	4.30	0.38	High
Error Reduction (ER)	4.34	0.40	High
Cost Reduction (CR)	4.31	0.40	High
Reduction of Risks in Working Process (RRP)	4.33	0.41	High
Reduction of Operation interruptions ROI)	4.32	0.40	High
Increase of Customer Value (ICC)	4.34	0.42	High

Table 2  
Path Analysis with Direct, Indirect and Total Effects  
(n=527)

Dependent Variable	Effect	Independent Variable			
		TROP	CP	ECTC	ECP
TO	DE	-	0.18*	-	-
	IE	0.20 (17.67)*	0.04 (17.67)*	-	-
	TE	0.20 (17.67)*	0.22 (107.87)*	-	-
CP	DE	0.90 (21.14)*	-	-	-
	IE	0.18 (9.63)*	0.20 (17.67)*	-	-
	TE	1.08 (17.67)*	0.20 (17.67)*	-	-
ECTC	DE	0.70 (6.09)*	0.23 (2.08)*	-	-
	IE	0.39 (4.06)*	0.20 (17.93)*	-	-
	TE	1.09 (17.93)*	0.43 (3.97)*	-	-
ECP	DE	0.03 (0.03)	0.82 (7.91)*	0.11 (1.46)	-
	IE	0.92 (8.18)*	0.17 (11.02)*	-	-
	TE	0.95 (18.50)*	0.99 (9.86)*	0.11 (1.46)	-

$\chi^2 = 78.30$ ,  $df = 72$ ,  $p\text{-value} = 0.28578$ , Relative  $\chi^2 = 1.088$ ,  $GFI = 0.98$ ,  $AGFI = 0.96$ ,  $RMR = 0.002$ ,  $SRMR = 0.013$ ,  $RMSEA = 0.013$ ,  $P\text{-Value for Test of Close Fit} = 1.00$ ,  $NFI = 1.00$ ,

$IFI = 1.00$ ,  $CFI = 1.00$ ,  $CN = 678.48$

R<sup>2</sup> for Endogenous Variable

VP	TRM	TSD	TTR	BCC	CPT
0.77	0.71	0.69	0.72	0.70	0.79

R<sup>2</sup> for Endogenous Variable

CMC	ISH	CBO	GR	AGT	WTR
0.77	0.79	0.65	0.80	0.82	0.77

R<sup>2</sup> for Endogenous Variable

ER	CR	RRP	ROI	ICC
0.72	0.66	0.57	0.63	0.53

R<sup>2</sup> for Structural Equations

TO	CP	ECTC	ECP
0.31	0.86	0.84	0.89

CORRELATION MATRIX BETWEEN LATENT VARIABLES

	TO	CP	ECTC	ECP
TO	1.00			
CP	0.93	1.00		
ECTC	0.91	0.88	1.00	
ECP	0.89	0.94	0.86	1.00

Note: The numbers in parentheses are t-test statistical value; \* is statistically significant at the 0.05 level ( $|t| > 1.96$ )

Table 3  
Hypothesis test results

No.	Hypothesis	Path Analysis	ผลการทดสอบ
H1:	H1: Enhancing Cross-Border Transportation Capabilities (ECTC) has a positive direct effect on Entrepreneur Capabilities Performance (ECP)	DE=0.11 TE=0.11	Reject hypothesis
H2:	H2: Transport Operation (TROP) has a positive direct effect on Enhancing Cross-Border Transportation Capabilities (ECTC)	DE=0.70 IE=1.09	Accept hypothesis
H3:	H3: Cooperation and Participation (CP) has a positive direct effect on Enhancing Cross-Border Transportation Capabilities (ECTC)	DE=0.23 IE=0.20 TE=0.43	Accept hypothesis
H4:	H4: Enhancing Cross-Border Transportation Capabilities (ECTC) mediates the positive effect of Transport Operation (TO) on Entrepreneur Capabilities Performance (ECP)	DE=0.03 IE=0.92 TE=0.95	Reject hypothesis
H5:	H5: Enhancing Cross-Border Transportation Capabilities (ECTC) mediates the positive effect of Cooperation and Participation (CP) on Entrepreneur Capabilities Performance (ECP)	DE=0.82 IE=0.17 TE=0.99	Accept hypothesis

Note: Statistically significant level of .05

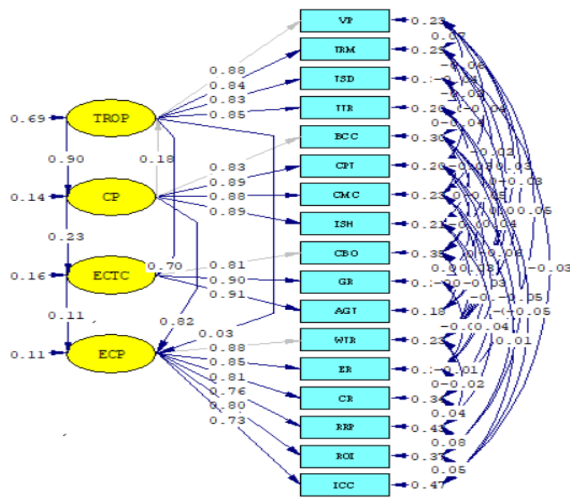

Chi-Square=78.30, df=72, P-value=0.28578, RMSEA=0.013

Figure 1. (A) SEM Analysis

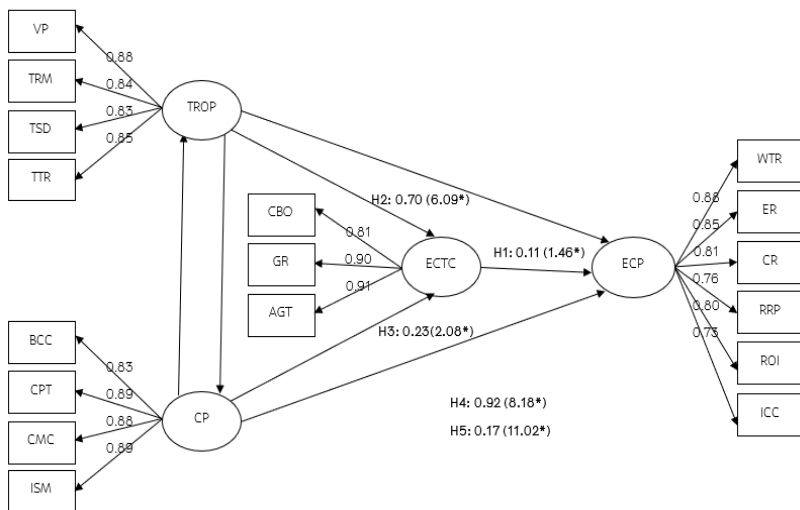

Figure 1. (B) SEM Analysis

## Conclusions

The results of the research can be summarized and discussed as follows:

### **Methods to enhance cross-border transportation capabilities of road freight entrepreneurs: Chong Chom permanent border crossing point, Thailand-Cambodia Cooperation and Participation**

( $\bar{X}$  =4.35). The important method is involvement of stakeholders ( $\bar{X}$  =4.38) which includes public sector participation ( $\bar{X}$  =4.41), for example, the government should have a meeting to discuss cross-border transportation with freight entrepreneurs to perceive about any problems ( $\bar{X}$  =4.48) and employee participation ( $\bar{X}$  =4.37), including the presence of customer involvement ( $\bar{X}$  =4.37) and coordination ( $\bar{X}$  = 4.35), including coordinating solutions ( $\bar{X}$  = 4.38), e.g., concluding the company's contracts with the customers for the transportation of goods to reduce potential denials of liability ( $\bar{X}$  = 4.50), including coordination of transportation ( $\bar{X}$  = 4.35) and maintenance ( $\bar{X}$  = 4.31), including communication ( $\bar{X}$  = 4.34), including communication with customers ( $\bar{X}$  =4.35), such as creating cooperation in work together to deliver goods to the destination on time ( $\bar{X}$  = 4.47) consistent with the qualitative research findings. It shows that companies need to cooperate and engage with the government, that is, employees must liaise with customs authorities. They must recognize customs formalities both inbound and outbound, cross-border freight documents, understand of cross-border shipping regulations strictly, and cooperate in customs procedures with customs in order not to affect the company.

### **Enhancing Cross-Border Transportation Capabilities**

( $\bar{X}$  =4.33). The important method is the government regulations ( $\bar{X}$  = 4.34), which is the implementation of the correct laws ( $\bar{X}$  =4.36), for example, there should be monitoring of government policy information and situation of Thailand and Cambodia to provide information for management in the organization ( $\bar{X}$  =4.44) and have expertise in customs ( $\bar{X}$  =4.34) and cross-border clearance operations ( $\bar{X}$  =4.33), including cargo release operations ( $\bar{X}$  = 4.37), such as processing transport documents crossing the border, information required at the checkpoint to be completed early so that documents and goods can be inspected and taken out of the border crossing point when it comes to calling queues ( $\bar{X}$  =4.44), employees are accountable and reliable ( $\bar{X}$  =4.32), including documenting formalities ( $\bar{X}$  =4.30) as well as agility ( $\bar{X}$  =4.33), i.e. employee agility and clarity of work procedures ( $\bar{X}$  =4.33), such as the sensitivity that employees should have COVID-19 testing, must be checked every time before

crossing the border for their own safety and society ( $\bar{X} = 4.43$ ), speed of solving problems ( $\bar{X} = 4.32$ ), such as employees should be alert and recognize problems that arise all the time ( $\bar{X} = 4.38$ ) as well as agile in assessing situations and implementing appropriate solutions ( $\bar{X} = 4.32$ ), e.g. employees need to solve problems that arise quickly, including adapting to the different cultures and practices of each country for efficient cross-border transport and achieving goals ( $\bar{X} = 4.36$ ). This is consistent with the qualitative research findings recommending that the companies must have training for their employees to understand the methods and procedures of transporting goods across borders in detail and in accordance with the rules and regulations in the transportation of goods across borders. For the processes in the transportation of goods across the border, the issue of cross-border shipping documents is an important first step in liaising with customers and governmental customs in order to expedite the process of customs clearance of goods across borders along with that the truck was released to cross the border in time according to the customer's schedule.

### **Transport Operation Process**

( $\bar{X} = 4.29$ ). The important method is tracking and reports ( $\bar{X} = 4.34$ ), including monitoring ( $\bar{X} = 4.32$ ), reporting methods ( $\bar{X} = 4.36$ ), for example, the entrepreneurs should have a supervisor to screen the data for work efficiency ( $\bar{X} = 4.45$ ) and real-time problem solving ( $\bar{X} = 4.35$ ) and vehicle readiness ( $\bar{X} = 4.28$ ) transport equipment ( $\bar{X} = 4.24$ ) facility readiness ( $\bar{X} = 4.31$ ), for example, there should be equipment, lifting equipment, loading and unloading goods and conveying to speed up operations in cross-border logistics ( $\bar{X} = 4.35$ ), including transportation risk management ( $\bar{X} = 4.28$ ), including risk management ( $\bar{X} = 4.27$ ), risk assessment and reporting ( $\bar{X} = 4.27$ ). Transport safety ( $\bar{X} = 4.31$ ), for example, a drainage system in the rainy season, which is the external environment of the Thai-Cambodian border trade under the ASEAN Community for transportation safety ( $\bar{X} = 4.38$ ). This is consistent with the qualitative research findings revealing that the companies must have a plan and a policy to operate in cross-border shipping by using information technology to help. They must train drivers to have knowledge of cross-border transportation routes. Modern technology must be used to transport goods quickly and upgraded. The data must be kept in a system and RFID technology must be used to manage trucks for quick management. When there is a problem in the transportation of goods, there is a halt which can solve problems quickly.

Therefore, in order to increase the capability of cross-border cargo transport at the Thai-Cambodian border checkpoint, in practice, the company must build cooperation and promote participation with those involved in the transport sector. Especially, the government sector and customers should operate in accordance with government regulations and the law on cross-border carriage of goods

strictly. Employees must be trained and sensitive to immediate problem solving. There are transport operations including vehicle preparation and tracking along with fast communication. This is in line with Monyepao (2015) and Weihua et al. (2019) indicating that cross-border freight capability must consist of the preparation of cross-border shipping documents, displaying information clearly and accurately in order to meet the customs conditions and regulations.

### **Enhancing Cross-Border Transportation Capabilities Model**

The structure of the model consists of four constructs: Enhancing Cross-Border Transportation Capabilities (ECTC) ( $\lambda = 0.83 - 0.92$ ), Transport Operation (TO) ( $\lambda = 0.81 - 0.87$ ), Cooperation and Participation (CP) ( $\lambda = 0.85 - 0.89$ ) and Transport Entrepreneur Capabilities Performance (ECP) ( $\lambda = 0.74 - 0.85$ ), as shown in Figure 1(A) and 1(B), which is a specific model to be used for enhancing cross-border transportation capabilities by road: Chong Chom permanent border crossing point, Thailand-Cambodia.

### **The Effect of Enhancing Cross-Border Transportation Capabilities (ECTC) on Entrepreneur Capabilities Performance (ECP)**

From Table 2 and Figures 1(A) and 1(B), it was found that ECTC ( $DE = 0.11$ ) had no direct effect on ECP. On the other hand, the study found that the sub-factors of the ECTC – TROP and CP, had a total effect on the ECP at a high level,  $TE = 0.95$  and  $TE = 0.99$ , which means that although ECTC does not have a direct positive effect on ECTC, the adoption of the model for cross-border freight transport will help transport operators to have a better performance in all aspects, such as waiting time reduction (0.88), error reduction (0.85), cost reduction (0.81), reducing the risks in operational processes (0.76), reduction of operational interruptions (0.80), and increase of customer 's value (0.73). Therefore, this model is suitable for use in cross-border freight forwarding companies.

### **Contributions**

Cross-border freight forwarders must plan and set guidelines as well as establish a strategy for cooperation and participation of stakeholders, both government sectors and customers. The government needs to organize a meeting to give entrepreneurs advices to solve problems in cross-border transportation, including correct government regulations and cross-border transport laws. There is a follow-up on government policies, customs, and cross-border formalities, product release inspection and transport operations processes that need to be tracked and reported to solve problems in real time.



### Future research direction

Research related to the application of information technology for cross-border transport, including cultural differences and international communication factors should be studied.. This may result in the capability of cross-border freight forwarding.

### References

- Amer. Jazayrli., Lenhardt. Johannes. (2015). The PILOOR Model: a guideline to mutually improve logistics performance in cross-border shipper-TPL provider relationships. Master Thesis, Level D, 15 credits Industrial Engineering and Management Master Program in Management of Logistics and Innovation. p. 1-61.
- Aunyawong, W., Wararatchai, P., & Hotrawaisaya, C. (2020). The influence of supply chain integration on supply chain performance of auto-parts manufacturers in Thailand: a mediation approach. *International Journal of Supply Chain Management*, 9(3), 578-590.
- Aunyawong, W., Wararatchai, P., Shaharudin, M.R., Hirunpat, A., & Rodpangwan, S. (2021). The mediating role of transportation practices during the COVID-19 crisis in Thailand. *The Open Transportation Journal*, 15(1), 170-181.
- Boyle, E., Humphreys, P. and McIvor, R. (2008), "Reducing supply chain environmental uncertainty through e-intermediation: An organisation theory perspective", *Int. J. Production Economics*, Vol. 114, pp. 347– 362.
- Burkovskis. Raimondas. (2010). Efficiency of freight forwarder's participation in the process of transportation. *TRANSPORT*. 23(3), p. 208–213.
- Chang, Y., Wilkinson, S., Potangaroa, R. and Seville, E. (2020), "Managing resources in disaster recovery projects", *Engineering, Construction and Architectura Management*, Vol. 19 No. 5, pp. 557-580.
- Chofer, Oseph J. (2017). Reengineering the seaportcontainer truck hauling process Reducing empty slot trips for transport capacity improvement. The current issue and full text archive of this journal is available. 19(5), p. 750-782.
- Chong Chom Customs checkpoint Surin Province. (2020). [Online]. Accessible from : <http://chongchom.customs.go.th>. Date of retrieval 7 October 2020.
- Christopher, M. and Peck, H. (2004), "Building the resilient supply chain", *International Journal of Logistics Management*, Vol. 15 No. 2, pp. 1-13.
- Department of Customs, (2021). "Border crossing" [Online]. Accessible from : <http://www.customs.go.th/Retrieved> . March 7 March 2021.
- Department of Land Transport. (2019). Department of Land Transport Raise the standard of truck transportation service quality. Q Mark Expands Quality Certification. Access from [www.dlt.go.th/th/public-news/view.php?\\_did=2348](http://www.dlt.go.th/th/public-news/view.php?_did=2348), Search Date January 1, 2017.

- Dey. C. Kakan., Yan. Li. Yan., Xujie. Wang. Yue. Wang. (2016). A Review of Communication, Driver Characteristics, and Controls Aspects of Cooperative Adaptive Cruise Control (CACC). *IEEE Transactions on Intelligent Transportation Systems*. 17(2). p. 491-509.
- Esper, T.L., Fugate, B.S. and Davis-Sramek, B. (2007), "Logistics learning capability: sustaining the competitive advantage gained through logistics leverage", *Journal of Business Logistics*, Vol. 28 No. 2, pp. 57-81.
- Fulzele, V., Shankar, R, and Choudhary, D. (2019), "A model for the selection of transportation modes in the context of sustainable freight transportation", *Industrial Management & Data Systems*, Vol. 119 No. 8, pp. 1764-1784.
- Giannakis, M. and Louis, M. (2011). A multi-agent-based framework for supply chain risk management, *Journal of Purchasing & Supply Management*, Vol. 17, pp. 23-31.
- Gligor, D.M. and Holcomb, M.C. (2012), "Understanding the role of logistics capabilities in achieving supply chain agility: a systematic literature review", *Supply Chain Management: An International Journal*, Vol. 17 No. 4, pp. 438-453.
- Hang, Yen Low. (2010). UCP 600: the new rules on documentary compliance. The current issue and full text archive of this journal is available. 52(3). p. 193-210.
- Hanson. Robin., Medbo. Lars., & Johansson. I. Mats. (2015). Order batching and time efficiency in kit preparation. journal is available on Emerald Insight. 35(1), p. 143-148.
- Hinkka, Ville, Maiju Häkkinen and Jan Holmström., et al. (2015). Supply chain typology for configuring cost-efficient tracking in fashion logistics. *The International Journal of Logistics Management*. 26(1), 2015 p. 42-60.
- Ismail and Zul-Atfi. (2019). Optimising the safety of road transport workers on IBS building construction projects: a review. *Social Responsibility Journal*. 15(6), pp. 837-851.
- Jenei, I., Demeter, K. and Gelei, A. (2006), "The effect of strategy on supply chain configuration and management practices on the basis of two supply chains in the Hungarian automotive industry", *International Journal of Production Economics*, Vol. 104, p. 555-570.
- Jesús. García-Arca., J. Carlos. Prado-Prado., & Arturo. J. Fernández-González. (2018). Integrating KPIs for improving efficiency in road transport. The current issue and full text archive of this journal is available on Emerald Insight. 48(9). p. 931-950.
- Jinxin. Liu., Hui. Xiong., Tinghan. Wang., et al. (2020). Probabilistic vehicle trajectory prediction via driver characteristic and intention estimation model under uncertainty. The current issue and full text archive of this journal is available on Emerald Insight.
- Kim. Chang-Bong., Hong-Uk. Chun., & Seung-Ha. Kwon. (2016). Impact of application factors of the AEO program on its performance. *Journal of Korea Trade*. 20(4), p. 332-348.

- Kedkanok Chamawan et al., (2018). Developing Business Quality Benchmarks Thai logistics in the category of international freight forwarders. *Journa Suthiparita*. 32(104), 26-39.
- Kim. Chang-Bong., Hong-Uk. Chun., & Seung-Ha. Kwon. (2016). Impact of application factors of the AEO program on its performance. *Journal of Korea Trade*. 20(4), p. 332-348.
- Kuehnhausen., Martin and Frost, Victor S. (2011). *Journal of Systems and Information Technology*. 13(4), p. 369-388. Emerald Group Publishing Limited.
- Lin, Y., Wang, Y. and Yu, C. (2010), "Investigating the drivers of the innovation in channel integration and supply chain performance: A strategy orientated perspective ", *Int. J. Production Economics*, Vol. 127, pp. 320–332.
- Liu. Jia., & Xie. Kefan. (2015). Preparation and scheduling system of emergency supplies in disasters. This research is supported by China Scholarship Council and National Natural Science Foundation of China. 44(3). p. 423-439.
- Mac Cormack, A. and Forbath, T. (2008), "Learning the fine art of global collaboration", *Harvard Business Review*, Vol. 86 No. 1, pp. 24-26.
- Melnyk, S.A. (2007), "Lean to a fault?", *Council of Supply Chain Management Professional's Supply Chain Quarterly*, Vol. 2007 No. 3, pp. 29-33.
- Meyer. G. Gerben., Buijs. Paul., Szirbik. B. Nick., et al. (2013). Intelligent products for enhancing the utilization of tracking technology in transportation. The current issue and full text archive of this journal is available. 34(4). p. 422-436.
- Monyepao. K. (2015). The Impact of Non-Operationalization of the Sadc Protocol and International Transport Agreements On Cross Border Road Transport Movement In The Sadc Region. *Proceedings of the 34th. Southern African Transport Conference*. p. 636-644.
- Muerza, V., Larrodé, E. and Moreno-Jiménez, J.M. (2017), "Identification and selection of ICTs for freight transport in product service supply chain diversification", *Industrial Management & Data Systems*, Vol. 117 No. 7, pp. 1469-1484.
- Nadiya Mikula. (2012). Development tendencies of the new forms of cooperation in Ukrainian-Polish cross-border space. Department of the Institute of Regional Research NAS of Ukraine. p. 70-79.
- National Statistical Office. (2012). *Sampling and Estimation Techniques*, Office of Policy and Academic Affairs Statistics Statistical Methods Group. P.1-89.
- Nawata. Kengo., Yamaguchi. Hiroyuki., & Aoshima. Mika., (2020). Team implicit coordination based on transactive memory systems. The current issue and full text chive of this journal is available on Emerald Insight. 26(7/8). p. 375-390.
- Nimit Siriwan. (2011). Factors Affecting Logistics Management Efficiency of the transport operator cargo by truck Transportation routes in the central and eastern regions. Rajabhat University Ayutthaya.

- Nualkaw, S., Wararatchai, P., Sommanawat, K., & Aunyawong, W. (2021). Service value of transportation service providers for e-commerce products in the new economy era: creativity, society and environment. *Psychology and Education Journal*, 58(4), 2016-2023.
- Perego Alessandro, Sara Perotti and Riccardo Mangiaracina. (2011). International journal of Physical Distribution & Logistics Management. 41(5), p. 457-483.
- Pintuma, S., & Aunyawong, W. (2021). The effect of green supply chain management practices on environmental, operational and organizational performances of seafood manufacturers in Thailand. *International Journal of eBusiness and eGovernment Studies*, 13(2), 33-48.
- Ponomariov. Branco., & Kingsley. Gordon. (2012). The Development Of A Relational Orientation To Consul Tants Amongst Project Mangers. *Journal Of Public Procurement*. 11(3), p. 354-387.
- Prabhakaran. and Sudhakar M.S., (2015). "Offset-based curvilinear path estimation for mid vehicle collision detection and avoidance system using MARS". *International Journal of Intelligent Unmanned Systems* Vol. 7 No. 2, pp.54-71.
- Rahman, Shams and Nie, Oing. (2012). Graduate students' perceptions of supply chain skills for supply chain managers. *Benchmarking: An International Journal*. 21(2), p. 276-299.
- Schmiz, Antonie. (2011). Migrant self-employment between precariousness and self-exploitation. *ephemera: theory & politics in organization*, 13(1). P. 53-74.
- Schoenherr, T., Tummla, V.M.R. and Harrison, T.P. (2008). Assessing supply chain risks with the analytic hierarchy process: Providing decision support for the offshoring decision by a US manufacturing company, *Journal of Purchasing & Supply Management*, Vol. 14, pp. 100-111.
- Setthachotsombut, N., & Aunyawong, W. (2020). Agro-tourism service enhancement in Nakhon Pathom Province, Thailand: on capability increasing of the hospitality of agriculturists. *International Journal of Supply Chain Management*, 9(6), 1403-1414.
- Soonthornpipit, H., Kortana, T., & Aunyawong, W. (2021). Expansion opportunities of community enterprises in Thailand to China. *Psychology and Education Journal*, 57(8), 86-97.
- Srisawat, S., & Aunyawong, W. (2021). Development of business performance under environmental uncertainty: lesson from Thailand's Eastern Economic Corridor. *International Journal of Entrepreneurship*, 25(5), 1-10.
- Stadie Seifi, M., Dellaert, N.P., Nuijten, W., Van Woensel, T. and Raoufi, R. (2014), "Multimodal Freight transportation planning: a literature review", *European Journal of Operational Research*, Vol. 233 No. 1, pp. 1-15.
- Suthasinee Roopkaew and Phonsan Phosrithong, (2019), Competency analysis required for training and Development Baggage Conveyor System Officer, Airports of Thailand Public Company Limited, according to the association's agreement international air transport. *EAU Heritage Journal Social Science and Humanities*, 10(2), 241-254.

- Tardiff and Ontario. (2017). The strictira; basis of alpha-tropomyosin linked (Asp 230 Asn) familial dilated cardiomyopathy. *Journal of Molecular and Cellular Cardiology* 108. p.127–137.
- Tariq Al-Shbail., & Aini Aman. (2017). E-government and accountability How to mitigate the disorders and dysfunctions of accountability relationships. The current issue and full text archive of this journal is available on Emerald Insight. 12(2), p. 155-190.
- Trade and investment information center with neighboring countries. (2020). [Online]. Accessible from: <http://bts.dft.go.th>. Date of retrieval 5 October 2020.
- Wagner, S.M. and Neshat, N. (2010), "Assessing the Vulnerability of Supply Chains Using Graph Theory", *International Journal of Production Economics*, Vol. 126 No. 1, pp. 121-129.
- Wattananarangsarn Pitchaya and Suthanyarak Chonwit. (2016). Optimizing the performance of 4 star hotel staff in Siam Square area. *Valaya Longkorn Research and Development Journal under royal patronage*. 11(1), 71-79.
- Weihua et al., (2019). "Coronavirus disease 2019 in pregnancy". *International Journal of Infectious Diseases*. 376-383.
- Wisedsin, T., Jermstiparsert, K., Thitrat, P., & Aunyawong, W. (2021). Role of advanced manufacturing technology, human capital and employee empowerment to enhance manufacturing industry supply chain performance. *International Journal of Supply Chain Management*, 9(2), 411-418.
- Yeo, J. (2020). Beyond Immigration and Customs Enforcement: Understanding Interorganizational Collaboration for Border Management. *Journal of Borderlands Studies*, 1-23. DOI: 10.1080/08865655.2020.1833231