

How to Cite:

Kanagaraju, P., Ajaykumar, B., & Karthikeyan, K. (2022). Self aided system in health care monitoring using IOT. *International Journal of Health Sciences*, 6(S5), 2686–2694.
<https://doi.org/10.53730/ijhs.v6nS5.9231>

Self aided system in health care monitoring using IOT

Dr. P. Kanagaraju

Assistant Professor in Computer Science and Engineering, K.S.Rangasamy College of Technology, Tiruchengode-637 215, Namakkal District, TamilNadu, India.

B. Ajaykumar

Students of Computer Science and Engineering, K.S.Rangasamy College of Technology, Tiruchengode-637 215, Namakkal District, TamilNadu, India

K. Karthikeyan

Students of Computer Science and Engineering, K.S.Rangasamy College of Technology, Tiruchengode-637 215, Namakkal District, TamilNadu, India

Abstract--The main aim of this paper is to develop long-range medical health care system and also helps us to monitor the patient's body 24/7 by using IoT. This technology can track physiological indicators from the patient's body at regular intervals. Hospital staffs face severe difficulty when they are faced with the task of taking care of multiple patients simultaneously. Problems such as waiting in the queue, travelling time, moving patient, waiting for doctor etc. are some of the issues faced by the patients. During an emergency, the situation might get worse. Monitoring the critical patient 24/7 is very important for reducing life threatening risk. This paper has a significant impact on the health-care industry. Continuous and real-time structural health monitoring can help to reduce the risk of collapse and the consequences of potentially lethal scenarios. This system is responsible for collecting pulse, body temperature and heart bit from the patient's body and send the data by using WIFI-Module. Biosensors interfaced with the micro controller will monitor patient's vital health. If any of the sensor's present threshold value is exceeded beneath, an alert will be sent to doctor and the patient's caretaker. The monitoring system comprise of the sensor network in which the sensor nodes a Re-equipped with different biometric sensors, sensor data will be regularly transferred to hospital database from which it is upload to doctor's mobile continuously using IOT devices. The proposed outcome of the research is to give patients with suitable and effective health care.

Keywords---Long-range, Physiological parameters, Waiting, Life threatening, Biosensors.

1. Introduction

1.1 Overview

In present day, people are suffering from various kinds of disease and many health problems. Hospital staffs face severe difficulty when they are faced with the task of taking care of multiple patients simultaneously. Problems such as waiting in the queue, travelling time, moving patient, waiting for doctor etc. are some of the issues faced by the patients. During an emergency, the situation might get worse.

Monitoring the critical patient 24/7 is very important for reducing life threatening risk. Wireless applications have had a significant impact on health-care services. In medical science wireless application has several numbers of advantages such as, ease of use, reduced risk of infection and enhanced mobility. This approach makes it simple to keep track of multiple patients at the same time. The goal of this study is to develop an IoT-based health monitoring system that can perform a range of activities within time, accuracy, and cost restrictions. Though the health-care industry is slower to adopt IoT (Internet of Things) than other industries, IoT in medicine is intended to keep people safe and healthy, with the primary goal of lowering health-care costs in the future years. The Doctor can change the patient's prescription if necessary. Furthermore, in the event of an emergency, the doctor can take fast action.

1.2 Characteristics of the work

- Reading Temperature
- Monitoring Heart-beat
- Buzzer Alert
- Mobile App Notification

1.3 Objective of the work

- In the absence of the docs, the affected person can't seek advice from the docs because of which emergency state of affairs can also be created.
- Because of the rise in fitness issues in the modern world, every man or woman's personal fitness tracking is considered extremely important. The public's fitness is struggling the maximum due to a more and more confused lifestyle.
- A large-scale pandemic, along with COVID19, places large pressure on international fitness systems, wreaks havoc on prone populations, and poses a severe risk to groups all at some stage in the world

2. Reason Why Healthcare

Needs IOT

- Reducing emergency room waiting time
- Tracking patients, staff, and inventory
- Enhancing drug management
- Enhancing patients' participation while offering them satisfactory result
- Ensuring the availability of critical hardware
- Turning data into actions
- Greatly promoting preventive care
- Improving the patient's health

3. Characteristics of internet of things

3.1. Intelligence

IoT is intelligent because it combines algorithms and processing, software and hardware. Ambient intelligence improves the skills of IoT devices, letting them reply intelligently to a given scenario and supporting them in wearing out precise tasks. Regardless of ways widely wide-spread superior generation is, IoT intelligence is greater involved approximately manner contact. Device interoperability is finished the use of massive enter mechanisms and a graphical consumer interface, The usage of a graphical user interface and large input techniques is used to complete the consumer and tool interaction.

3.2. Connectivity

Connectivity empowers Internet of Things by bringing together everyday objects. Connectivity of these objects is pivotal because simple object level interactions contribute towards collective intelligence in IoT network. It enables network accessibility and compatibility in the things. With this connectivity, new market opportunities for Internet of things can be created by the networking of smart things and applications.

3.3. Dynamic Nature

The primary goal of the Internet of Things is to collect data from its surroundings, which is accomplished through dynamic adjustments that occur between devices. These devices' states alter dynamically, such as when they slumber and wake up, and whether they are connected or not. In addition to the context of gadgets such as temperature, place and speed. The number of gadgets changes dynamically with a person, area, and time, in addition to the device's country of origin.

3.4. Enormous scale

The variety of gadgets that have to be controlled and speak with each other could be a way greater than the variety of gadgets presently connected to the Internet. The management of data created by those devices, as well as its interpretation for software reasons, are both critical responsibilities that will become increasingly important. Gartner (2015) confirms the substantial scale of IoT withinside the predicted document wherein it said that five million new matters get linked each day and In2016, 6.4 billion linked matters could be in use across the world,

growing 30% from 2015. The document additionally forecasts that the variety of linked gadgets will attain 20.8 billion through 2020.

3.5. Sensing

IoT would be impossible without sensors that detect and measure changes in the environment in order to provide data that can be used to report on their status or even interact with it. Sensing technologies enable the development of capabilities that reflect a true understanding of the physical environment and the people who inhabit it. Although sensing data is fundamentally analogue input from the physical world, it has the potential to provide a profound understanding of our complex environment.

3.6. Heterogeneity

Heterogeneity in Internet of Things as one of the key characteristics. Devices in IoT are based on different hardware platforms and networks and can interact with other devices or service platforms through different networks. IoT architecture should support direct network connectivity between heterogeneous networks. The key design requirements for heterogeneous things and their environments in IoT are scalabilities, modularity, extensibility and interoperability.

3.7. Security

IoT devices are clearly vulnerable to security risks. As we benefit from the IoT's efficiency, innovative experiences, and other benefits, it would be a mistake to ignore the IoT's security concerns. There is an overwhelming level of transparency and privacy problems associated with IoT. It is essential to stable the endpoints, the networks, and the facts this is transferred throughout it all approach developing a safety paradigm.

4. Literature review

[1] IoT based system plays the key role in medical appliances. For that reason, many researchers are trying to develop numerous IoT based medical appliances. A researcher implemented a patient monitor system, which aim is to gather data for clinical research and academic studies. Public Health Service (PHS) will enable faster and safer preventive care, lower overall cost, improved patient centered practice and enhanced sustainability. In this work, an electronic device is described which monitors the elderly people's health in their own home with the help of wireless sensor technology. Implement a remote healthcare system is monitoring the patient health condition by using the medical care provider instrument.

[2] This paper proposed that, there are several applications in the market that offer health care at home. Nowadays m-Health applications received great attention from the researchers and developers, where different services and suggestions are offered. The authors proposed a mobile application which enables to improve the communication between healthcare providers and healthcare recipients, the application was designed in order to perform the text, audio and video communication between two individuals, but it does not provide health services at home. A mobile application-based system propounded in Provides information about the hospital, allocate appointment with a doctor, medication reminder, BMI calculator, emergency call but this application only developed to

both hospitals and patients, therefore, they do not provide direct access to the results of the lab and do not provide a direct communication mechanism with the healthcare provider. Another mobile application of health care system for patients But the limitation of this work is that it cannot provide a direct access to laboratory results because it is not managed by the hospital itself.

[3] These studies defined how a person's blood strain turned into measured the usage of Keep in Touch, which turned into related to an Android-primarily based totally clever telecall smartphone the usage of Near Field Communication. Inductive and magnetic coupling are used to make it work. All of the facts is uploaded to the clever telecall smartphone after Keep in Touch has acquired the readings. Because the facts are in a closed loop, its miles transferred to a steady internet site in which every person can display their blood strain levels. IOIO-OTG Microcontroller turned into used to assess the person's electrocardiogram and display the readings from everywhere at the planet. The readings of Electrocardiogram studying tracking had been displayed the usage of an Android application. The IOIO-On the Go microcontroller may also ship facts to an Android tool through a USB connection, Bluetooth connection, or Near Field Communication (NFC). After the facts has been captured, its miles dispatched to the smartphone's Android application. The place in which the ECG values may be tracked.

[4] This paper gives a primary classification to assist the visually impaired people to travel independently without external aid and monitoring real-time location information of these individuals, a wearable electronic device is presented in this paper. The technology can detect obstacles in the user's path, such as humps in the ground and moving objects. Furthermore, the device recognizes the unexpected fall and alerts the user's guardian. The system is comprised of ultrasonic sensors, a Passive Infrared Sensor (PIR) motion sensor, an accelerometer, a smartphone application, a microcontroller, and a data transmission device. The microcontroller transmits the data to the user's smartphone via Bluetooth module. The smartphone app creates aural instructions to guide the user through the process. The application also updates the current location of the user to keep track and notifies the guardians when the user falls down or in distress, for users to navigate using exact vocal instructions, the method has shown to be extremely successful and efficient. Overall, the developed system will make the visually impaired people and their guardian's feel much safer and confident.

[5] This paper talks, the condition of health of a patient and gathers a sequential health history of the patient. The data gathered does not particularly relate to a specific therapeutic condition, instead, it gives the necessary information to determine patterns which are characteristic of healthy patients as well as to those who are sick. The data collected is periodically transferred to a database in which it is stored alongside similar health histories for other patients. It is the application of mobile computing technologies for improving communication among patients, physicians, and other health care workers. As mobile devices have become an inseparable part of our life it can incorporate health care more flawlessly to our everyday life. It empowers the delivery of accurate medical information anytime anywhere by means of mobile devices.

5. Proposed Methodology

There are three phases in this methodology. Those are Measuring Body Temperature, Measuring Heartbeat and Alerts and Notification.

5.1. Measuring Body Temperature

This sensor enables us to keep track of the patient's body temperature on a frequent basis. This Temperature Sensor LM35 series is a precision integrated-circuit temperature device with a linearly proportional output voltage to the temperature in degrees Celsius. Compared to linear temperature sensors calibrated in Kelvin, the LM35 device has the benefit of not requiring the user to subtract a high constant voltage from the output to obtain convenient Centigrade scaling. To attain typical accuracies of 14°C at room temperature and 34°C throughout a temperature range of 55°C to 150°C, the LM35 gadget requires no external calibration or trimming.

5.2 Measuring Heartbeat

The patient's low and high pulses are output by the IR-based heart beat pulse sensor. When a finger is inserted between the IR Transmitter and Receiver, the heart beat sensor produces a digital output of heart beat. The beat LED flashes with each heartbeat when the heart beat detector is operational. This digital output can be directly connected to the microcontroller to measure the BPM rate. At each pulse, it works on the idea of light modulation by blood flow via the finger. An infrared transmitter and receiver make up the sensor. The transmitter sends out an infrared ray, which is picked up by the receiver. When blood is pumped between the fingers at a rate that corresponds to the heartbeats, Infrared rays are prevented in the middle and released as needed. The detector signal changes with each heartbeat. This fluctuation is turned into electrical impulses and shown as a 0- or 5-volt DC output voltage. The output signal is indicated by a blinking LED that changes colour with each heartbeat.

5.3 Alerts and Notification

This module allows us to make a buzzer sound as an alert and send a telegram to the guardian or doctor. An Arduino buzzer is also known as a piezo buzzer. It's essentially a little speaker that can be directly connected to an Arduino. You may programme it to emit a tone at a specific frequency. The buzzer makes sound by using the piezoelectric effect in reverse. A telegram notification is a message that Android displays outside of your app's UI to provide the user with reminders, other people's communication, or other timely information from your app. Users can access your app or take action immediately from the notice by tapping it.

Working

IoT plays a major role in the medical sector. In the olden days people have walked miles with sickness in order to cure it by the help of a doctor. Doctors were not as available as now. Whereas nowadays the number of doctors is directly proportional to the number of patients a particular doctor has. So, one particular doctor has to keep tabs on several patients at the same time. What our paper presents is using IoT we can take off a part of burden or work from the doctor's shoulder. It helps him to reduce some work and time. So, we prepared an IoT

module which uses multiple sensors like temperature, heartbeat, buzzer etc. So, these particular sensors are connected to the Arduino board and ESP module which has an inbuilt Wi-Fi module.

Now the built Iot mechanism is kept nearby to the patient at home. The patients should not have any worries about going to hospital and check his/her condition regularly. The module is kept near the patient where it continuously monitors the patient's body temperature from his hands and the pulse using infrared rays through his wrists.

If there is an abnormality in the patient's condition. There is a buzzer attached to the module which helps the family members to identify the abnormality by providing a loud noise. And the notification of the abnormality is sent to the doctor's telegram where he monitors his patient's condition on a regular basis. This is the general working of the Iot module. But there are drawbacks to this such as if the patient is away from the module the temperature shown will be the room's temperature and the heartbeat will be the last recorder heartbeat or zero and the buzzer would start the loud noise for no abnormality. So, the module should be nearby so that the accuracy of the reading will be precise.

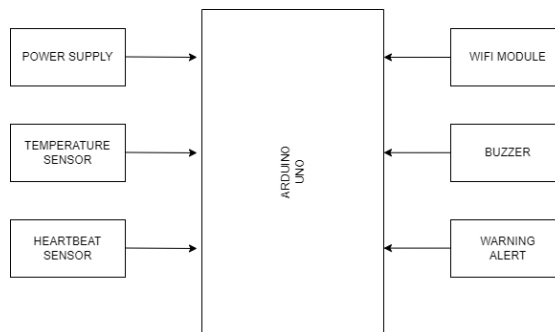

Figure 1. Block Diagram

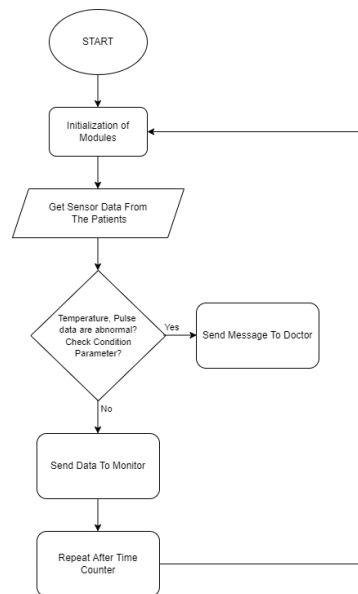

Figure 2. Flow chart

6. Conclusion

With the advancement of biomedical sensors, we are now able to monitor the patient's real-time body temperature, heart rate, and other physiological information. The temperature sensor and pulse sensor module are used for acquiring medical information from the outside, and then converts them to digital signals. Thus, the project is to monitor and detect the patient's real-time body temperature, heart rate information's, and transmit them to the concerned doctor. In this paper, our main concern was ensuring the uninterrupted health monitoring system for the patients. This project was proposed prototype model. Our main goal was to focus on monitoring patient health monitoring. By using the system, the professional can monitor, advice and diagnose their patient and family member before arriving to the emergency. Hence, the professional and family member can monitor their patient from a remote location at any time. Android application is used for monitizing the patient. Before beginning of the project, every sensor was calibrated individually. Each of the signal analyzed by taking different data. All the observed signal was matched by experimental signal and the users got the output from the system through a message. We can use this system in real life and people will be benefited. This system is user-friendly and cost effective.

6.1 Scope for future development

A device with a sensor that can interact with the physical world while also providing data to the Internet is referred to as an IoT unit. All of these IoT-based healthcare devices can connect with one another to perform critical actions that could save a life or provide timely assistance. IoT devices can even grow in such a way that way that it is very easy to monitor one's health like having it installed

with our mobile whenever we use fingerprint sensor our health monitoring will be done. This is a process which can be developed because we use the fingerprint sensor a lot on daily basis.

If the finger print sensor acts a trigger to do the monitoring for a split second and sms the condition of the patient so that the condition of the patient is done in that instant and can also be checked regularly. But there comes an issue that it cannot be accurate and requires a lot of maintenance. There are minor drawbacks for whatever we develop we have to find where the drawbacks are the least.

References

- [1] Obaidulla-Al-Mahmud, Md. Kausar Khan : Internet of Things (IOT) Based Smart Health Care Medical Box for Elderly People, International Conference for Emerging Technology (INCET), volume:2,pp:19-25(2020)
- [2] Eshraq Ali Alweshail, Hajar Brahim: "A Smartphone Application to Provide the Health Care Services at Home Eshraq Ali Alweshail, Hajar Brahim", IEEE access, pp:100-107,(2020)
- [3] Sudha.V, Shaziya Banu. A "Survey on Patient Health Monitoring System Using IOT & Arduino", International Journal of Electrical, Electronics and Computer Systems access, volume:6, Issue:1, pp:2225-2230(2018)
- [4] R.Nivetha, S.Preethi "Smart Health Monitoring System Using IOT For Assisted Living Of Senior And Challenged People", International Journal Of Scientific & Technology Research Volume:9, Issue 02(2020).
- [5] Gulam Gaus Warsi, Kanchan Hans "IOT Based Remote Patient Health Monitoring System", International Conference on Machine Learning, Big Data, Cloud and Parallel Computing, pp: 76-80(2019)
- [6] Subhra Shriti Mishra, Akhtar Rasool "IOT Health care Monitoring and Tracking: A Survey", IEEE access, pp:13-16(2020)
- [7] Dan Liu, Hue-Hong Hsieh "Analysis on Functional Demand of Mobile-Health APP for Elders", 2nd IEEE Eurasia Conference on Biomedical Engineering, Healthcare and Sustainability, volume:3, pp:40-45, (2020)
- [8] Gloren S. Fuentes, Grace Lorraine D. Intal "E-healthcare: Child Monitoring Health System (CHMS) with SMS Functionality", IEEE 7th International Conference on Industrial Engineering and Applications, pp:50-56(2020).
- [9] Rinaritha, K., & Suryasa, W. (2017). Comparative study for better result on query suggestion of article searching with MySQL pattern matching and Jaccard similarity. In *2017 5th International Conference on Cyber and IT Service Management (CITSM)* (pp. 1-4). IEEE.
- [10] Mr.Anand D.Acharya, "IOT based Health Care Monitoring Kit", International Conference on Computing Methodologies and Communication, pp:110-115(2020)
- [11] Sasipriya Saminathan, K.Geetha "A Survey On Health Care Monitoring System Using IOT", IEEE access, volume:9, pp:700-706(2020)