



Relationship between Resistivity and Soil Strength based on Geoelectric Data (Case Study at Cassa Villa Jimbaran)



I Nengah Simpen^a, Ni Putu Gita Bonita Dewi^b, I Nyoman Aribudiman^c

Article history: Received 10 December 2017, Accepted in revised form 20 March 2018, Approved 10 May 2018,
Available online 26 May 2018

Correspondence Author^a



Keywords

Cassa Villa Jimbaran;
Geoelectric;
Resistivity;
Soil strength;
Wenner configuration;

Abstract

Geoelectric method was applied in geophysical research to know the relationship between resistivity with soil strength based on geoelectric data has been conducted at Cassa Villa Jimbaran, Badung, Bali. The study lies in the position of 8°46'50,6" LS and 115°10'02,6" BT. The data was collected by injecting an electric current inside the Earth's surface using a Wenner configuration with a path length 148.8 meters. The data was processed using SiberTool Software to export *.d2d to *.dat file. Therefore, it can be read by Res2dinv software. The further data was processed using Res2dinv for data inversion. Thus, it was able to show the contour of cross-section of the trajectory. The research result was obtained resistivity value at position 51.15 was 6, 40 - 11, 98 Ωm. The data of the soil strength was applied Standard Penetration Test (SPT) method by drilling and taking soil samples then testing in the laboratory. The soil sample was taken at position 51.15. The soil strength test result was obtained about 6 - 5, 3 [(kg/cm)²] at a depth of 0, 58 - 20, 0 meters. The two magnitudes were analyzed to find the relationship in the form of the two poly nomialorde $y = -60,811 x^2 + 1433,4 x - 8442,4$ with correlation coefficient value 0, 9799. It means there was a correlation between resistivity values with soil strength. It is as well as to define the soil strength value can be reviewed based on resistivity especially limestone soil.

*e-ISSN : 2550-6986, p-ISSN : 2550-6994 © Copyright 2018. The Author.
SS Journals Published by Universidad Técnica de Manabí.
This is an open-access article under the CC BY-SA 4.0 license
(<https://creativecommons.org/licenses/by-sa/4.0/>)
All rights reserved.*

^a Department of Physics, Faculty of Mathematics and Natural Sciences, Udayana University, Bukit Jimbaran Badung, Bali Indonesia 80361

^b Department of Physics, Faculty of Mathematics and Natural Sciences, Udayana University, Bukit Jimbaran Badung, Bali Indonesia 80361

^c Department of Civil Engineering, Faculty of Engineering, Udayana University, Bukit Jimbaran Badung, Bali Indonesia 80361

Contents

Abstract.....	22
1. Introduction	23
2. Research Methods	23
Field Research.....	23
2.1 Soil Resistivity Research.....	23
2.2 Process of Data collection.....	24
3. Results and Analysis.....	24
3.1 Result.....	24
3.2 Soil Strength Research.....	25
3.3 Relationship between Resistivity with Soil Strength	26
4. Conclusion.....	27
Conflict of interest statement and funding sources.....	27
Statement of authorship.....	27
Acknowledgements.....	27
References.....	28
Biography of Authors.....	29

1. Introduction

The knowledge of the soil strength is needed in the design of a building *e.g.*, house, dam, and highway road. The investigation of the land forces becomes imperative prior to development. The soil strength can be defined as ground resistance to *fracture* by *shear stress*, or to deformation by *compression* stresses. It determines the *bearing capacity* of the soil against any existing building on it. It is affected by soil type (rock), moisture content, bulk density or pore size distribution, porosity, and particle size distribution [1,2]. The various methods are used to determine the soil strength *i.e.*, *Standard Penetration Test (SPT)*, *Dutch Cone Penetrometer Test (DCPT)*, and drilling. All methods cost are more than the electric-based investigation [1].

Electrical soil-based investigations have recently received important attention. This method costs less than conventional methods and does not damage the environment. The method result is a resistivity value. The resistivity and soil strength values are affected by porosity, ion content in material, mineral composition, density, saturation level [1,2,8]. The similarity of the soil variables with electrical resistivity seems interesting to do a research between resistivity with soil strength. Therefore, it will be looked for a relationship between resistivity with soil strength. The resistivity data were obtained based on geoelectric method, the soil strength data was obtained based on drilling result. However, to be noticed is the presence of the seawater intrusion in the study area. In the case of seawater intrusion, the relationship between resistivity and soil strength can not be interpreted [2,9]. The relationship between resistivity and soil strength is still rare [2]. This research location was at Cassa Villa Jimbaran Bali.

2. Research Methods
Field Research
2.1 Soil Resistivity Research

Soil resistivity research is applied a geoelectric method. It is one of the geophysics that studies the nature of the electricity flow in the soil by injecting the electric current (I) into the soil and measuring the potential difference (V) that is generated. Inverted electric is electric current with the low frequency [3,10]. The schematic measurement of the geoelectric method can be seen in the following figure [4, 5]:

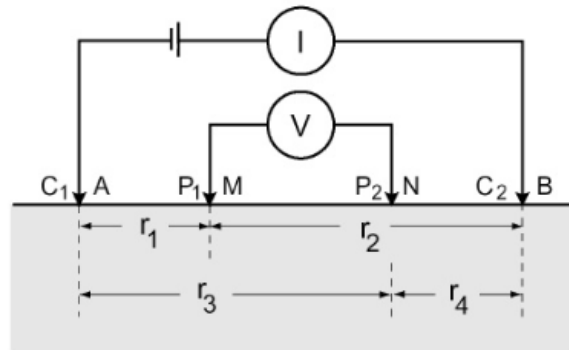

Figure 1. Schematic of geoelectric method measurement

The relationship between the measured current strength (I) with the potential difference that is generated (V) resulting rock resistivity (ρ) can be written [6,7]:

$$\rho = 2\pi K \frac{V}{I} \dots\dots\dots (1)$$

Wherein, (K) is (I) *i.e.*, the strength of the injected current and (V) is the potential difference, (ρ) is resistivity. The resistivity of the calculation results is an apparent resistivity. To obtain real resistivity, (ρ) data is needed to be analyzed with *Res2divn* program.

2.2 Process of Data collection

Data collection is applied *SkillPro* resistivity tool. Regarding *Werner configuration*, therefore, the placement of the electrode along with its displacement is like Figure 2 [5]. The measured physical quantities are the values of the electric current (I) and the potential difference (V) generated by injection of an electric current to the soil. After obtaining the measurement data, the data is processed with *Res2divn* program. The result is a cross-sectional resistivity contour.

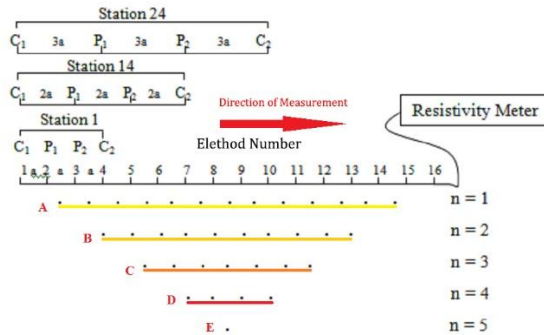

Figure 2. Data Collection with Wenner Configuration

3. Results and Analysis

3.1 Result

The results are obtained in accordance with the data collection process *i.e.*, cross-sectional resistivity contour unlike the Figure 3 below.

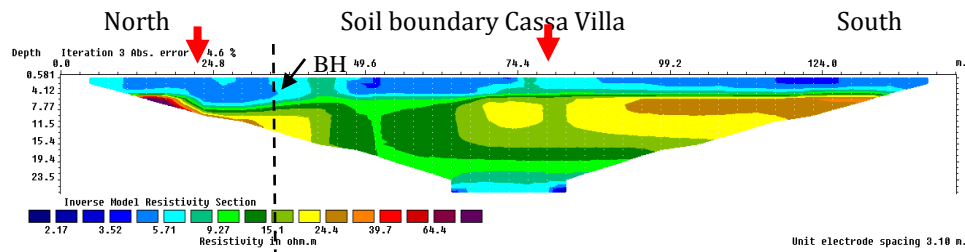

Figure 3. Cross-sectional resistivity contour of a measurement

Regarding the figure of the cross-sectional resistivity contours can be seen that at position 51, 15 meters indicated by the dotted line, is obtained resistivity data of each depth as follows:

Table 1
Depth resistivity data

No	Depth (m)	Resistivity (Ωm)
1	0,58	4,40
2	1,75	4,36
3	2,93	4,43
4	4,12	6,40
5	5,33	10,34
6	6,54	11,34
7	7,77	11,78
8	9,01	11,90
9	10,26	11,94
10	11,53	11,96
11	12,80	11,98
12	14,09	11,98
13	15,40	11,98
14	16,71	11,93
15	18,04	11,85

3.2 Soil Strength Research

The data of the soil strength is collected use *Standard Penetration Test (SPT)* method by drilling and taking soil samples, then testing in the laboratory. The soil sample is taken at position 51.15. The soil strength test results of each depth can be seen in.

Table 2
Strong pressure test result

No	Depth (m)	Soil Strength (kg/cm^2)	Soil Type
1	0,58	3,0	Clay Lanau brownish
2	1,75	5	Rough sandy <i>cadus</i> brownish
3	2,93	3,5	Rough sandy <i>cadus</i> grayish
4	4,12	6	Hard Limestone white whitish
5	5,33	6	Hard Limestone white whitish
6	6,54	6	Hard Limestone brownish white
7	7,77	4,1	Limestone brownish white
8	9,01	3,25	Limestone brownish white

9	10,26	2,5	Limestone brownish white
10	11,53	2,1	Limestone brownish white
11	12,80	2	Limestone brownish white
12	14,09	1	Limestone brownish white, porous
13	15,40	1	Limestone brownish white, porous
14	16,71	3,1	Limestone brownish white
15	18,04	4	Limestone brownish white

Respecting the observations at the point of drilling generally is a limestone soil, however, there are white and some are white brown, hard, and porous.

3.3 Relationship between Resistivity with Soil Strength

Based on the above cross-sectional figure at the position of 51, 15 meters has obtained the value of resistivity, soil strength, and soil types that exist in the study area are predominantly brownish white limestone soil. Due to the limestone variation, some brownish white limestone is taken to find the relationship between soil strength and resistivity. The resistivity data and soil strength are taken seven data that is real and not contaminated with other layers that are at a depth of 7.77 to 18.04 meters. The election results are shown in Table 3 below.

Table 3
The value of resistivity and soil strength each depth

No	Depth (m)	Resistivity (Ωm)	Pressure Strength (kg/cm^2)	Soil Type
1	7,77	11,78	4,1	brownish white Limestone
2	9,01	11,90	3,25	brownish white Limestone
3	10,26	11,94	2,5	brownish white Limestone
4	11,53	11,96	2,1	brownish white Limestone
5	12,80	11,98	2	brownish white Limestone
6	16,71	11,93	3,1	brownish white Limestone
7	18,04	11,85	4	brownish white Limestone

Based on Table 3, it can be graph the *correlation between resistivity and soil strength* as follows:

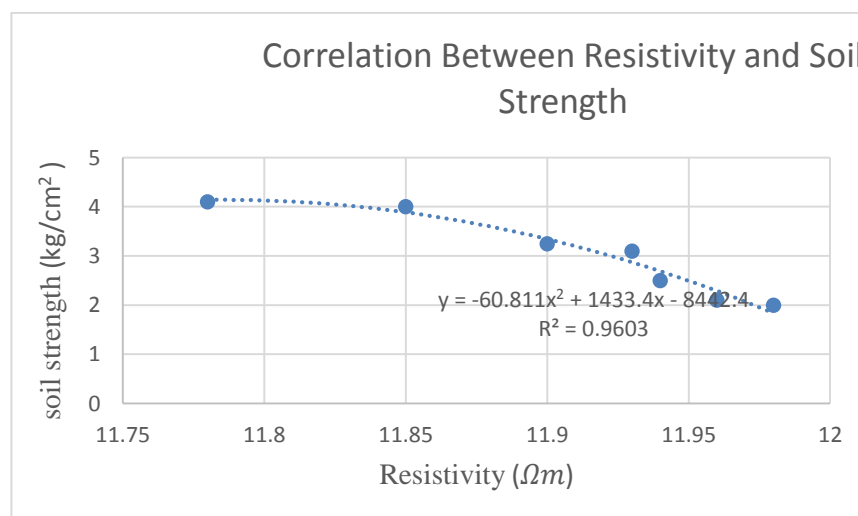

Figure 4. Graph of correlation between resistivity and soil strength

Based on Figure 4, there is a significant relationship between resistivity and soil strength. Regarding the graph shows the relationship between resistivity with soil strength in the form of second-order polynomial $y = -60,811 x^2 + 1433,4 x - 8442,4$ with value of correlation coefficient (R) is 0,9799. It means the existence of positive relation between the value of resistivity with soil strength $R > 0$. If it is viewed from the value of correlation, the relationship of both data value R close to 1. Thus, it defines that the resistivity value has a high relationship to soil strength. The value of determination coefficient of 0,9603 indicates that soil strength of 96,03% is determined by resistivity, while the rest of 3,97% determined other factors unlike contaminated with other soil types. Therefore, it can be stated the highest soil strength in the subsurface, the resistivity value decreases or the higher resistivity value in the subsurface, the soil strength decreases. The relationship of the two magnitudes is in the form of a second order polynomial. Apparently, the soil strength can be reviewed based on its resistivity especially limestone soil.

4. Conclusion

The conclusion is obtained in the present research:

- a) Resistivity value at depth of 4.12 - 18.04 meters at position 51.15 meters with a resistivity value of $5.71 \Omega\text{m} - 9.27 \Omega\text{m}$.
- b) The value of soil strength obtained is $6 \text{ kg/cm}^2 - 2 \text{ kg/cm}^2$ with brownish white soil limestone.
- c) There is a significant relationship between resistivity with soil strength in the form of second-order polynomial $y = -60,811 x^2 + 1433,4 x - 8442,4$ with correlation coefficient value (R) is 0,9799. It means the value of soil strength can be reviewed based on resistivity value especially limestone soil.

Conflict of interest statement and funding sources

The authors declared that they have no competing interest. The study was financed by personal funding.

Statement of authorship

The authors have a responsibility for the conception and design of the study. The authors have approved the final article.



Acknowledgments

Our thanks to the owner of Cassa Villa Jimbaran for the opportunity in conducting the research. Thank as well as to the Chairman and Staff of Soil Mechanics Laboratory, Department of Civil Engineering, Udayana University, all students of Department of Physics, Faculty of Mathematics and Natural Sciences, Udayana University, and all Students of Department of Civil Engineering, Faculty of Engineering, Udayana University who has helped in completing this research.

References

1. Sudha, K., Israil, M., Mittal, S., & Rai, J. (2009). Soil characterization using electrical resistivity tomography and geotechnical investigations. *Journal of Applied Geophysics*, 67(1), 74-79.
[View in \(Google Scholar\)](#)
2. Wafi, A., Santosa, B. J., & Warnana, D. D. (2014). Pemetaan Zona Lemah Menggunakan Metode Geolistrik Konfigurasi Wenner dan Dutch Cone Penetrometer Test (DCPT). *Jurnal Sains dan Seni ITS*, 3(2), B92-B95.
[View in \(Google Scholar\)](#)
3. Simpen, I., Sutama, I., Redana, I., & Zulaikah, S. (2016). Aquifer Porosity Prediction Base on Resistivity Data and Water Conductivity. *International Research Journal Of Engineering, IT & Scientific Research (IRJEIS)*, 2(5), 8 - 21. doi:10.21744/irjeis.v2i5.24.
[View in \(CrossRef\)](#)
4. Simpen, I. N., Redana, I. W., Pujianiki, N. N., & Umratul, I. (2017). Aquifers Selection to Aid Geoelectrical Methods on Drilled Well Building near the Beach. *International Journal of Physical Sciences and Engineering (IJPSE)*, 1(3), 41-50.
[View in \(Google Scholar\)](#) [\(CrossRef\)](#)
5. Loke, M. H. (1999). Electrical imaging surveys for environmental and engineering studies. *A practical guide to*, 2.
[View in \(Google Scholar\)](#)
6. Hendrajaya, L., & AVIF, I. (1990). Geolistrik Tahanan Jenis, Laboratorium Fisika BUmi. *Jurusan Fisika, Fakultas Matematika dan Ilmu Pengetahuan Alam Institut Teknologi Bandung*.
[View in \(Google Scholar\)](#)
7. Simpen, I., Sutama, I., Redana, I., & Zulaikah, S. (2017). Aquifer Hydraulics Parameters Determination regarding One Well Base on Geolistic Data (A Case Study in Bugbug Karangasem Bali). *International Research Journal Of Engineering, IT & Scientific Research (IRJEIS)*, 3(4), 105-112. doi:10.21744/irjeis.v3i4.520.
[View in \(CrossRef\)](#)
8. Sánchez, L. K. M., Hernández, E. H. O., Fernández, L. S. Q., & Párraga, W. E. R. (2018). Determination of Physical and Mechanical Properties of Quarries Dos Bocas Mouths and Mine Copeto for High Resistance Concretes. *International Research Journal of Engineering, IT and Scientific Research (IRJEIS)*, 4(2), 33-40.
[View in \(Google Scholar\)](#)
9. Pérez, A. V., Briones, V. V., Viteri, C. G. V., & Gámez, M. R. (2017). Iberoamerica in Network, GIS & TIC. *International Journal of Social Sciences and Humanities (IJSSH)*, 1(3), 108-117.
[View in \(Google Scholar\)](#)
10. Omer, A. M. (2017). Sustainable Development and Environmentally Friendly Energy Systems. *International Journal of Physical Sciences and Engineering (IJPSE)*, 1(1), 1-39.
[View in \(Google Scholar\)](#)

Biography of Authors

	<p>Dr. I Nengah Simpen, M.Si. was born on Karangasem August 2, 1960. He is a lecturer in Department of Physics, Faculty of Science and Mathematics, Udayana University Denpasar Bali. He finished his Master degree from Bandung Institute of Technology, Bandung in 1993, and his Doctorate degree from Udayana University Denpasar Bali in 2016. He as well as teaches at Civil Engineering Department, Faculty of Engineering, Udayana University Denpasar, Bali-Indonesia. He is interested in Geophysics/Groundwater. His E-mail is simpen.nengah@yahoo.com</p>
	<p>Ni Putu Gita Bonita Dewi was born on Yehembang Jembrana Bali, May 24, 1995. She Graduated in Physics Department, Faculty of Science and Mathematics, Udayana University, Denpasar Bali. She is interested in Earth Physics, especially in Groundwater and Geoelectrics. She will soon complete her studies in Department of Physics, Udayana University. E-mail is bonitagitha@yahoo.co.id</p>
	<p>I Nyoman Aribudiman was born in Tabanan on March 2, 1972. He is a Lecturer in Department of Civil Engineering, Faculty of Engineering, Udayana University Denpasar, Bali-Indonesia. He is interested in Geophysics and Geotechnics. E-mail is naribudiman@yahoo.com</p>